

# Visible Light Tomography Diagnostic for Imaging of Spatial Profiles of Plasma Emission in the Gas Dynamic Trap Divertor

Ya.Borissenko<sup>1, a)</sup>, A.Lizunov<sup>1, b)</sup>, N.Vasileva<sup>1</sup>, A.Khilchenko<sup>1</sup>, D.Moiseev<sup>1</sup>,  
P.Zubarev<sup>1</sup>

<sup>1</sup> *Budker Institute of Nuclear Physics  
Akademika Lavrentieva prospect 11, Novosibirsk, Russian Federation*

<sup>a)</sup>[yaborisenko10@gmail.com](mailto:yaborisenko10@gmail.com)

<sup>b)</sup>[a.a.lizunov@inp.nsk.su](mailto:a.a.lizunov@inp.nsk.su)

**Abstract.** One of the most important research directions on the Gas Dynamic Trap (GDT) magnetic mirror [1] is a complex study of the divertor physics. The foundation stone of this research program is a study of physical processes in a volume of divertor with expanding magnetic field lines. The exploration of the region near the plasma absorber is also considered. Because of neutralization of the plasma flux on the absorber surface, the adjacent plasma layer is characterized by a high density of atomic and molecular particles. Such a compound considerably affects the whole system particle balance, thus having an effect on the electrostatic potential spatial distribution. Measurement of intensity distributions of light emitted by atoms of plasma offer a direct instrument to observe the dynamics of this plasma component. In this paper, a new visible light tomography diagnostic system is proposed. The two-dimensional tomographic system is designed, constructed and installed on GDT. An avalanche photodiode (APD) based detector for visible light wavelength is used. The main features of the system are following: (i) a high sensitivity in 650–660 nm wavelength region; (ii) a time resolution better than 1  $\mu$ s; (iii) a fan-beam geometry of lines of sight (LOS). All measurement modules were absolutely calibrated on a test stand and the optical system throughput was measured to get absolute intensity values. First measurement results are also discussed in the paper.

## INTRODUCTION

One of the best methods to study spatiotemporal structure of plasma is noncontact optical diagnostics. Visible-light imaging systems having a big number of viewports [2, 3] deliver rich arrays of data in physical experiments on modern plasma confinement devices. To study complex physical processes in divertor of GDT, the new 2D tomography system was proposed. Due to recombination processes in divertor, plasma emits light that is collected and registered by the system. Analogically to widely spread on tokamaks Fast Ion D-Alpha (FIDA) diagnostics, the new system was called Warm Ion D-Alpha (WIDA). This multichannel optical diagnostic is designed to study of dynamics of spatial profiles of atomic density in magnetically confined plasmas. The observation geometry considered in the paper, corresponds to measurements of light emission intensity by a large-diameter plasma flowing along expanding magnetic field lines in the GDT divertor. The main system requirements coming from physical tasks:

- time resolution of approximately 1  $\mu$ s;
- high sensitivity in 650–660 nm wavelength region;
- high spatial resolution.

According to preliminary investigations, APD based detector seems to provide an optimal performance in a wide range of expected experimental conditions.

## EXPERIMENTAL SETUP

In the Fig.1, the general scheme of the diagnostic system is shown. The optical system consists of two diagnostic bundles and collects light along 42 lines of sight (21 LOS in each bundle). The first bundle called “WIDA-diameter” covers plasma region from one edge to the opposite one. The second bundle called “WIDA-radius” provides a spatial coverage from the center of the plasma flux to the edge. The region where lines of sight of two bundles intersect with each other represents the area of best tomographic reconstruction accuracy. Angular aligning unit in each diagnostic bundle allows to change angle setting in two directions. The optical and signal recording system has a modular design with seven identical three-channel measurement modules in each bundle.

Previously, no comprehensive measurements of plasma spatial profiles in the divertor were done. The projected WIDA diagnostic is deemed as an important instrument in a forthcoming study of plasma confinement in a GDT divertor, which is to resolve transverse spatial modes of oscillations and their phase-frequency structure. Data coming from existing diagnostics, allows to derive some constraints for expected spatiotemporal properties of the measured atom density. Namely, signals of line density from interferometers in the divertor and the central GDT cell, signals from a large array of magnetic probes and visible-light CCD camera images provide a reliable basis for the following assumptions: (i) the transverse density profile has an axis of symmetry and (ii) the oscillation frequency band lays inside the range 0..1 MHz. The coverage of the “WIDA-diameter” bundle is quite consistent with this physical task. The current diagnostic setup (see Fig.1) also includes the “WIDA-radius” optical system that primarily aims at a better radial resolution within a “scrape off layer” in planned experiment to study the divertor physics. Thanks to a modular design, the line-of-sight pattern can be changed at a minimum manufacturing cost. For most applications, a viewing geometry with two identical wide-overlapping bundles is looking the most efficient.

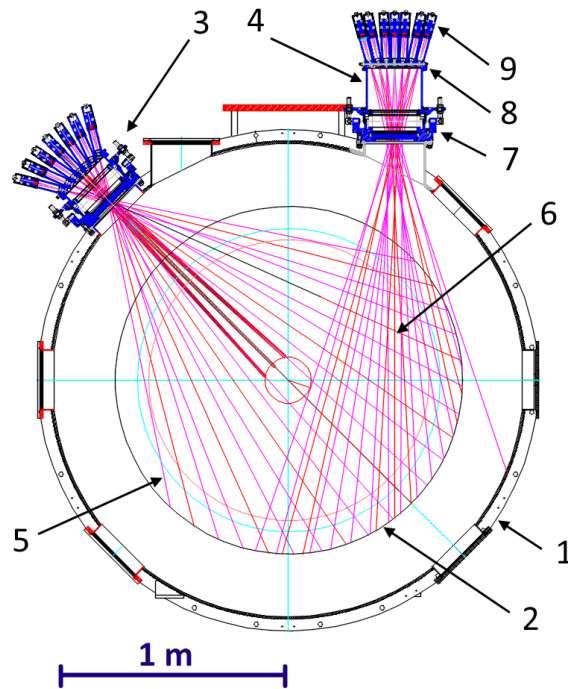

**FIGURE 1.** Layout of the optical 2D tomographic diagnostic: 1 – cross section of the vacuum vessel of the plasma installation, 2 – plasma boundary, 3 – “WIDA-diameter” bundle, 4 – “WIDA-radius” bundle, 5 – line of sight, 6 – area of best accuracy of tomographic reconstruction, 7 – two-axis angular aligning unit, 8 – measurement module holder with temperature stabilization, 9 – three-channel standard measurement module.

In the Fig.2, the drawing of the measuring module is presented. Input light goes through a narrowband interference filter. The present setup for observation of  $H\alpha$  and  $D\alpha$  is based on filters with the central wavelength of 656.2 nm and the FWHM of 1 nm. The diagnostic allows switching on detection of another wavelength range by simply changing the filter set. Passing the filter, light is gathered by a plano-convex lens with a 25.4 mm diameter and a 100 mm focal length. Three APDs Hamamatsu S12053-10 are nested in an electronics box to register the incoming light signal.

Hamamatsu S12053-10 diodes are characterized with a high quantum efficiency of 80% at 620 nm and a low dark current of 0.2 nA thus providing a respectable signal-to-noise ratio (SNR) for the actual number of photon detected within the time frame of 1  $\mu$ s. Because of a strong temperature dependence of both the dark current and multiplication for an APD, the base holder parts in diagnostic bundles are maintained at a constant temperature using distilled water flowing in the circuit with a recirculating chiller. APDs operating mode with multiplication ratio of 50 was chosen to get the biggest SNR possible. Each channel in module has its own two-stage transimpedance amplifier with 3.2 MHz signal bandwidth and  $2 \times 10^5$  V/A responsivity.

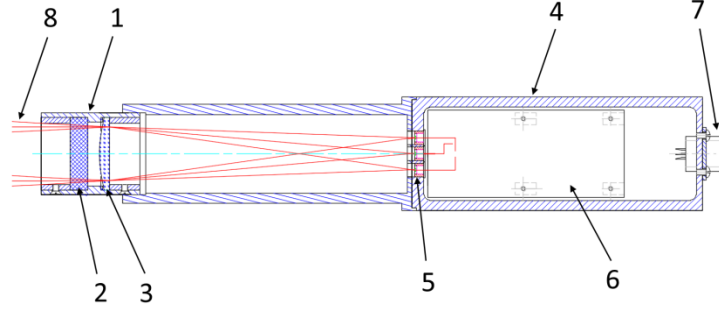

**FIGURE 2.** Three-channel measurement module: 1 – optical assembly, 2 – narrowband interference filter, 3 – plano-convex lens, 4 – electronics box, 5 – APDs, 6 – printed circuit board with amplifiers, 7 – power and signal connectors, 8 – input light rays.

## CALIBRATION RESULTS

Preliminary calibrations were made to enable precise measurements in experiment on GDT. Specifically, we studied the SNR dependence on diode reverse voltage and defined V/W responsivity coefficients for every channel in calibration measurements of an absolute intensity.

The same reverse voltage is applied to three APD across a module, thus it is essential to find optimal voltage value from a standpoint of SNR maximization. This paper describes results of calibration of a sample three-channel module, where the optimal reverse voltage had been determined as 152 V. The maximal SNR of approximately 85 presents the effective dynamic range of measurements [4]. Important to note, that the noise voltage is dominated by a shot noise and an APD excess noise, but not the amplifier noise.

A special optical stand was built for an absolute calibration of APD modules. On the stand, a similar light signal is applied to an APD under testing and a factory-calibrated reference photodiode Thorlabs FDS100, which spectral responsivity characteristic is documented. A continuous wave red laser (635 nm) was used as light source. The reference diode was provided with a current amplifier with a precisely known gain. Final responsivity coefficients for a sample measurement module were defined as following:

$$R_{APD\#1} = 4.16 \cdot 10^6 \pm 51 \cdot 10^3 \frac{V}{W} \quad (1)$$

$$R_{APD\#2} = 4.03 \cdot 10^6 \pm 49.03 \cdot 10^3 \frac{V}{W} \quad (2)$$

$$R_{APD\#3} = 3.89 \cdot 10^6 \pm 46.63 \cdot 10^3 \frac{V}{W} \quad (3)$$

Thus, the absolute calibration measurements were done by determining the responsivity coefficients for each measurement channel at optimal reverse voltage level. Also, during the experiment on GDT the temperature stabilization of each measurement module is provided and reverse voltage applied to each module is online controlled and kept at certain level with precision of 0.1 %. The design of quick in-situ calibration system is planned to improve the accuracy of experimental measurements.

## FIRST EXPERIMENTAL RESULTS

First experimental results are shown in this section, were obtained using the first produced measurement module having responsivities shown above. Three lines of sight laid in a vertical plane: LOS#1 – directed to the bottom, LOS#2 – central line, LOS#3 – directed to the top. The angle between central line and side lines of sight was  $4.2^\circ$ . This measurement module was installed in the GDT divertor. For collecting pilot physical data, we used a recent experimental campaign devoted to study of axial plasma losses and neutral gas density properties.

Fig.3 and Fig.4 shows processed signals measured in the GDT shot #40123. In these figures, one can see the absolute density of excited neutrals with a dynamics resolved with the time resolution of  $1 \mu\text{s}$ . Some specific oscillations of the light intensity signal are evident in the presented pictures. The cause of these oscillations is more likely connected with azimuthal rotation of the plasma flow or its transverse oscillations. These signals were obtained in operating regime of GDT with additional injection of molecular deuterium in the divertor plasma. This regime was used to display an effect of gas conditions in divertor on plasma confinement properties. On the shot statistics accumulated so far, one can note that acquired signals indicate complicated spatiotemporal structure of plasma in divertor. In some shots signals are in-phase, but in many shots their phases deviate, see Fig.4. A more comprehensive physical analysis will be done in follow-up experiment sessions with the full-scale WIDA bundles.

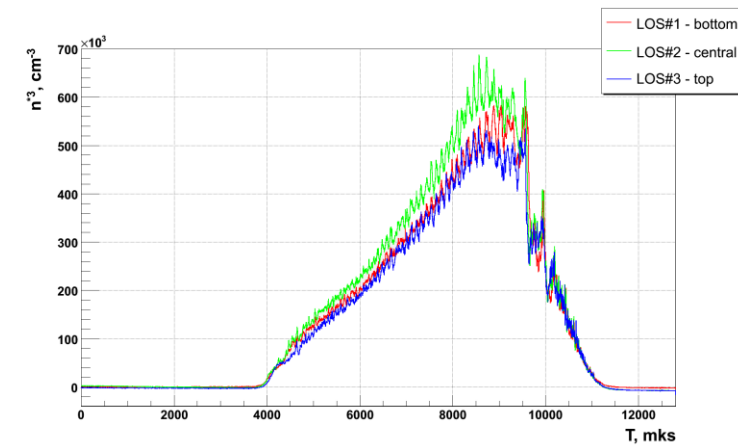

FIGURE 4. Signals obtained in shot #40123.

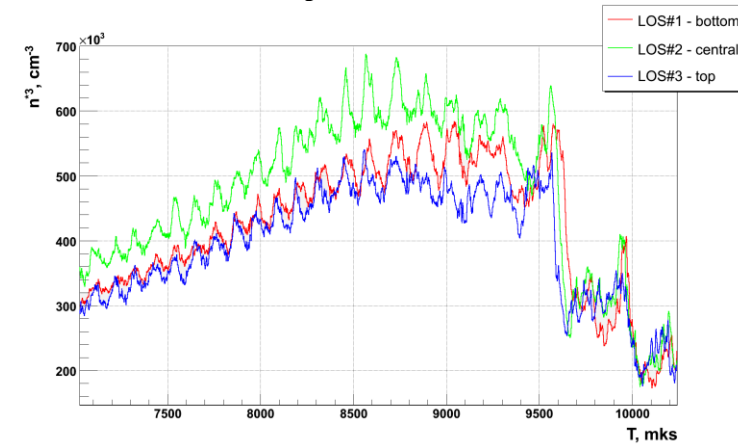

FIGURE 5. Signals obtained in shot #40123 (scaled).

## **SUMMARY**

According to work done, the main statements can be formulated:

- the new 2D tomography system is designed, constructed and installed on gas dynamic trap divertor;
- the calibration measurements and commissioning of new diagnostic system are done;
- first measured signals in divertor have 5-7 kHz oscillations that correspond to plasma oscillations measurements in central cell of GDT done by using magnetic probes and other diagnostics;
- the comprehensive analysis of spatiotemporal structure of observed plasma oscillations and their physical interpretation are next big tasks;
- the multichannel data processing and tomographic reconstruction are to be done.

## **REFERENCES**

This work was supported by the Russian Science Foundation (project N 14-50-00080).

- [1] A. Ivanov, V. Prikhodko, Plasma Phys. Control. Fusion **55**, 063001 (2013).
- [2] L. C. Ingesson, V. V. Pickalov et. al., Rev. Sci. Instrum. **66**, 622 (1995).
- [3] Y. Liu, A. Yu. Kostrioukov et. al., Rev. Sci. Instrum., **74**, 2312 (2003).
- [4] D. Dunai, S. Zoletnik et. al., Rev. Sci. Instrum., **81**, 103503 (2010).