

Spin Physics Detector



Spin Physics Detector at NICA: Status & Outlooks

Victor T. Kim

**Petersburg Nuclear Physics Institute
NRC "Kurchatov Institute", Gatchina, Russia**



Российская Академия Наук

**СЯФ ОФН РАН
Сессия-Конференция
«Физика Фундаментальных Взаимодействий»**

NICA: Nuclotron-based Ion Collider Facility

$$p^\uparrow p^\uparrow : \sqrt{s} \leq 27 \text{ GeV}$$

$$d^\uparrow d^\uparrow : \sqrt{s} \leq 13.5 \text{ GeV} \quad U, L, T$$

$$d^\uparrow p^\uparrow : \sqrt{s} \leq 19 \text{ GeV} \quad |P| > 70\%$$

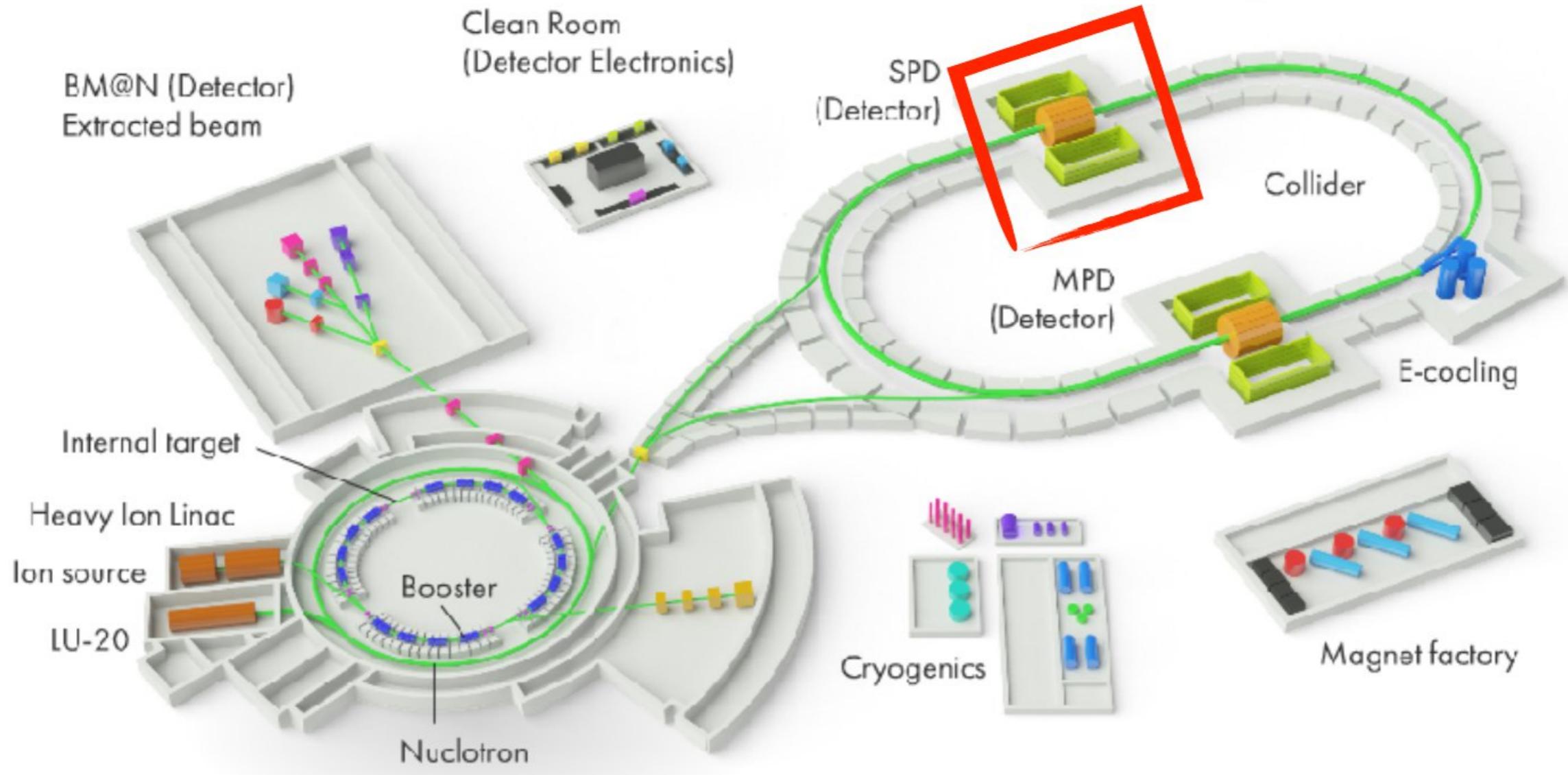
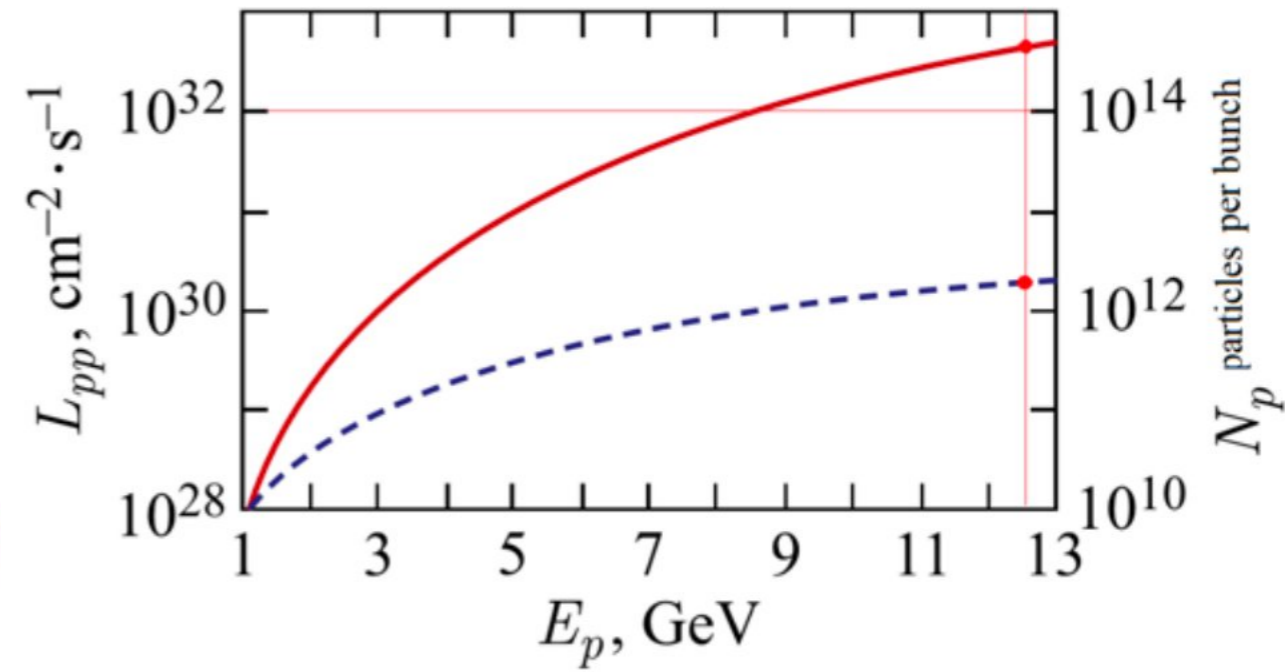

SPD at NICA Collider

Spin Physics Detector (SPD):
polarized pp- and dd- collisions at high luminosity

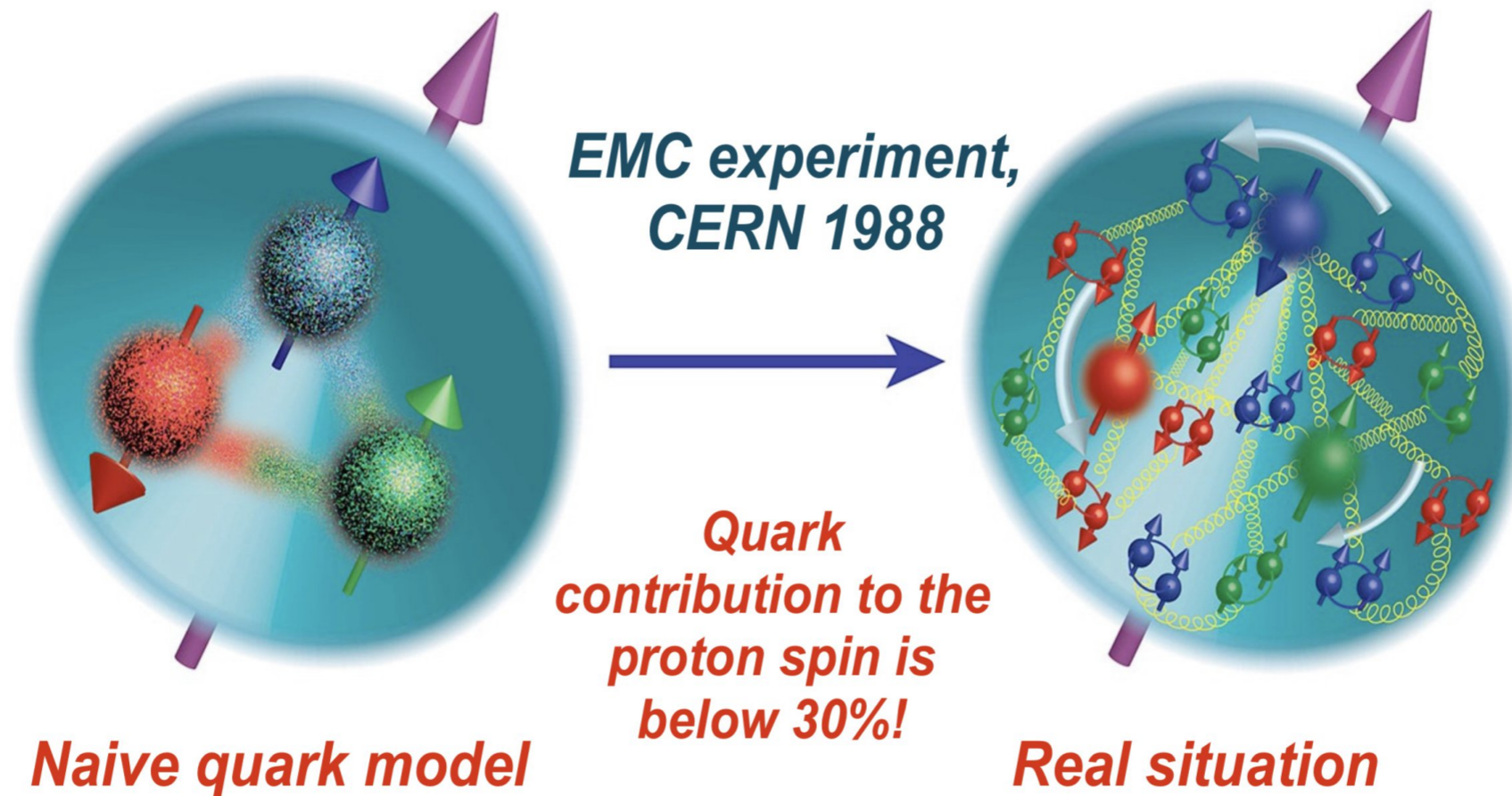

SPD NICA experiment is aimed at studying the properties of strong interactions in the nonperturbative region, at measuring the proton and deuteron spin structures, and at the development of a three-dimensional picture of the nucleon.

SPD NICA is unique in its methodology, breadth of coverage and variety of tasks.



- ▶ **Spin Physics Detector (SPD) at NICA** (<http://spd.jinr.ru>):
a universal setup for comprehensive study of
polarized and unpolarized gluon content of proton and deuteron
in polarized and unpolarized high-luminosity pp- and dd- collisions at $\sqrt{s} \leq 27$ GeV
- ▶ **Complementing main probes: charmonia (J/Psi, higher states), open charm and direct photons** in inclusive and semi-inclusive modes
- ▶ **SPD can reveal significant insights on:**
 - **gluon helicity structure**
 - **unpolarized gluon PDF at high x in proton and deuteron**
 - **gluon transversity in deuteron**
- ▶ **Comprehensive physics program for the initial period of data taking (can be performed even at reduced energy and luminosity)**

Search for New Physics:

- ▶ **Search for new particles and interactions** beyond the Standard Model
- ▶ **Search for new dynamics** within the Standard Model

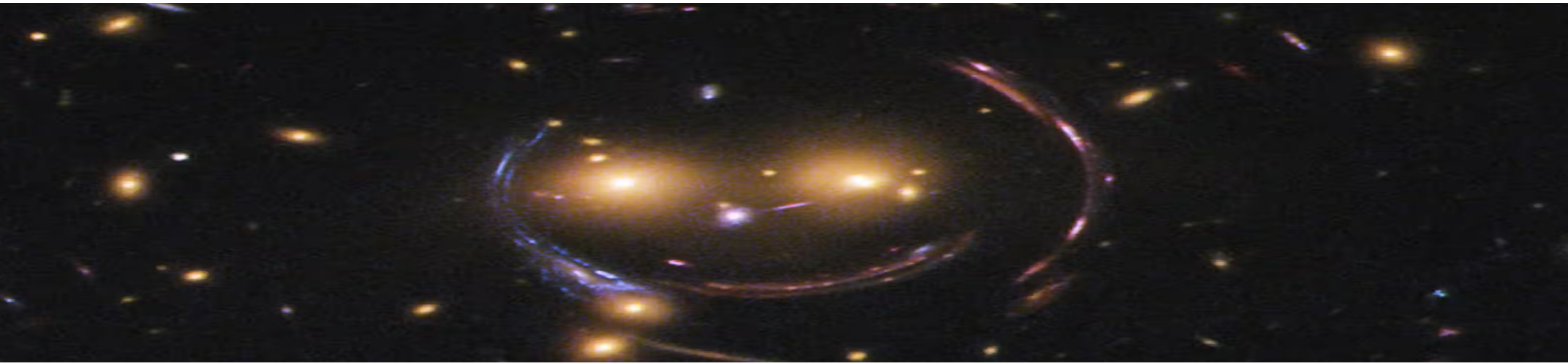

- proton mass -> the visible Universe mass

Electroweak Higgs boson provides:

quark mass $\sim 15 \text{ MeV} \approx 20\%$ of the visible Universe mass

↳ quark-gluon dynamics of nucleon structure provides:

$\sim 80\%$ of the mass of the visible Universe!

- nucleon size:

quark model ->

huge neutron EDM exceeding 10^{12} observed value

Why Spin?

Spin: pure quantum characteristics

spin: no classical analog

spin observables

- > **hadron wave functions**
- > **process amplitudes**

“proton spin crisis” :

quark model -> only 1/3 of proton spin

Spin: challenging delicate properties

"Experiments with spin have killed more theories than any other single physical parameter"

Elliot Leader, Spin in Particle Physics, Cambridge U. Press (2001)

"Polarisation data has often been the graveyard of fashionable theories. If theorists had their way they might well ban such measurements altogether out of self-protection."

J. D. Bjorken, Proc. Adv. Research Workshop on QCD Hadronic Processes, St. Croix, Virgin Islands (1987).

**Spin Physics Detector (SPD) (<http://spd.jinr.ru>):
A Universal Detector at NICA Collider**

➔ SPD Main Goals:

**understanding strong interactions using polarized
and unpolarized pp- and dd- collisions $\sqrt{s} < 27$ GeV**

- 3D structure of proton and deuteron, in particular, PDF and TMD at large x

A. Arbuzov et al. ,Prog. Part. Nucl.Phys. 119 (2021) 103858 e-Print: [2011.15005](https://arxiv.org/abs/2011.15005) [hep-ex]

**➔ In addition, wide research program for particular and nuclear physics
in the initial 1st Stage of SPD operation is planned**

V.V. Abramov et al., Phys. Part. 52 (2021) 1044, e-Print: [2102.08477](https://arxiv.org/abs/2102.08477) [hep-ph]

TMD - Parton Distribution Function with longitudinal momentum

TMD - Transverse Momentum Distribution–

parton distribution with transverse momentum

$p\uparrow p\uparrow$ -mode \rightarrow

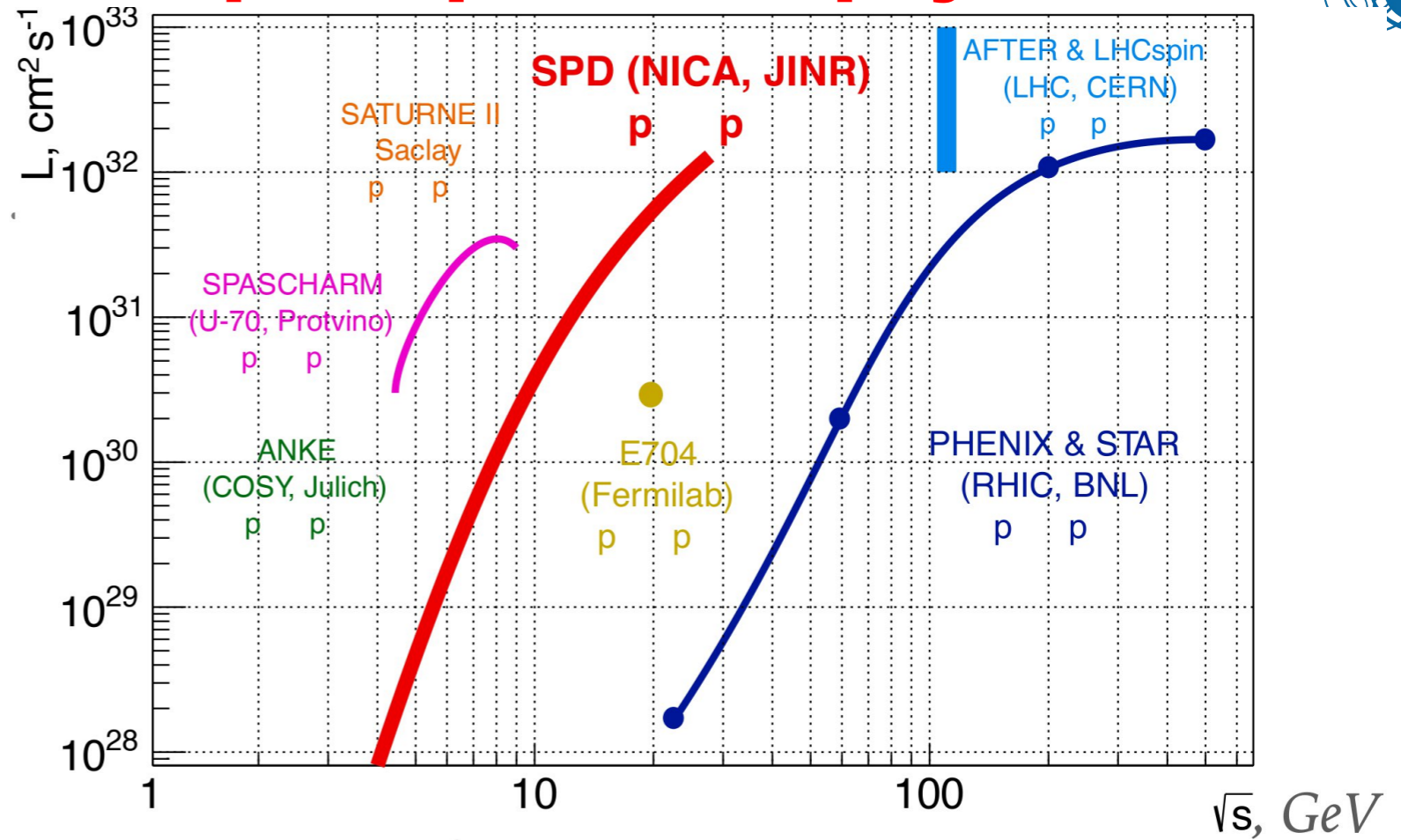

Experimental facility	SPD @NICA	RHIC	EIC	AFTER @LHC	LHCspin
Scientific center	JINR	BNL	BNL	CERN	CERN
Operation mode	collider	collider	collider	fixed target	fixed target
Colliding particles & polarization	$p^\uparrow-p^\uparrow$ $d^\uparrow-d^\uparrow$ $p^\uparrow-d, p-d^\uparrow$	$p^\uparrow-p^\uparrow$	$e^\uparrow-p^\uparrow, d^\uparrow, ^3\text{He}^\uparrow$	$p-p^\uparrow, d^\uparrow$	$p-p^\uparrow$
Center-of-mass energy $\sqrt{s_{NN}}$, GeV	≤ 27 ($p-p$) ≤ 13.5 ($d-d$) ≤ 19 ($p-d$)	63, 200, 500	20-140 (ep)	115	115
Max. luminosity, $10^{32} \text{ cm}^{-2} \text{ s}^{-1}$	~ 1 ($p-p$) ~ 0.1 ($d-d$)	2	1000	up to ~ 10 ($p-p$)	4.7
Physics run	>2025	running	>2030	>2025	>2025

\leftarrow SPD is unique in $d\uparrow d\uparrow$ -mode!

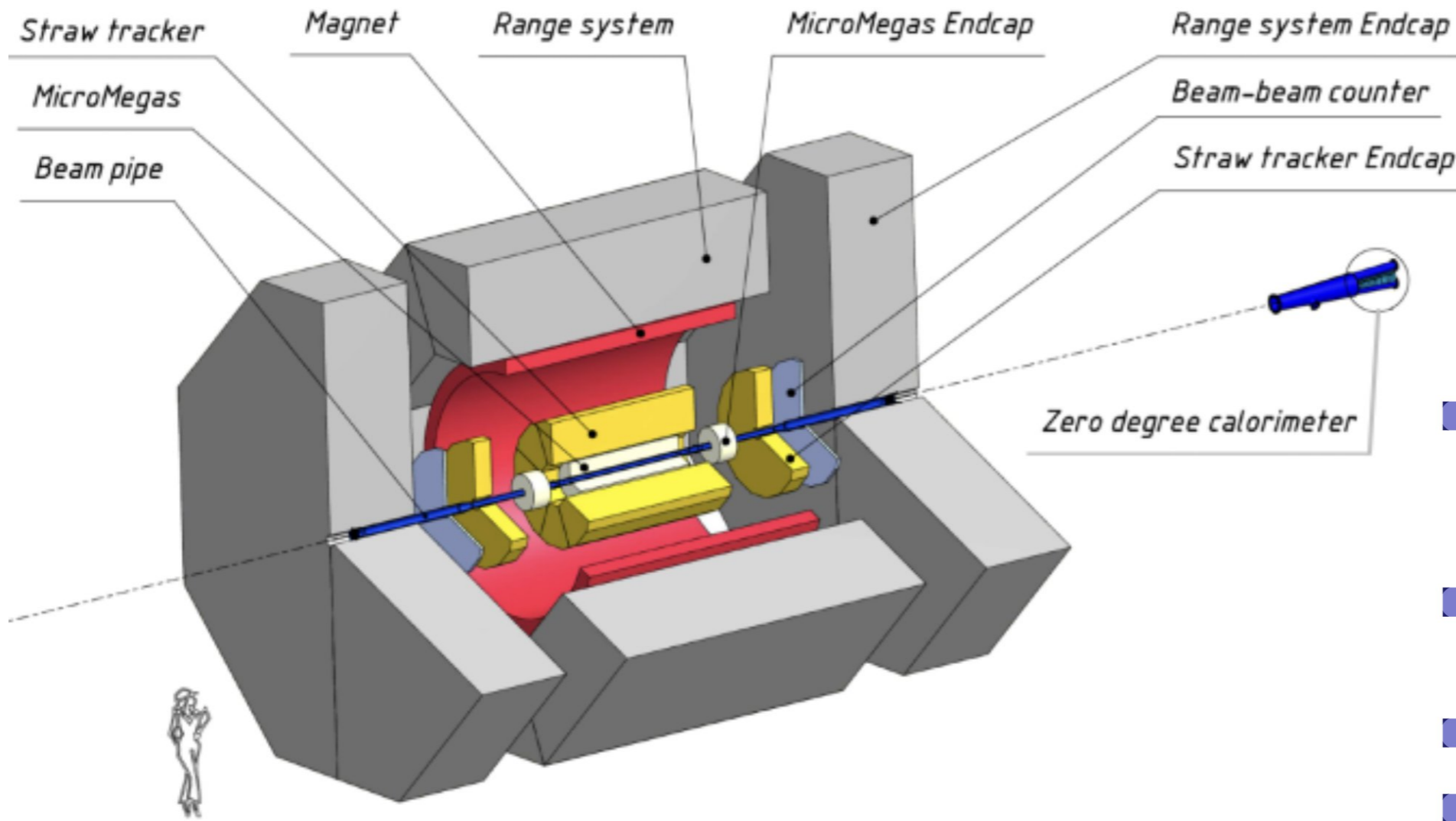

- Trackers: charged track and momentum, limited PID
- Range System: rough hadronic calorimeter, muon/ hadron separation

- Possible light ion collisions alongside pp, dd
- Up to $\sqrt{s} = 1.0$ GeV and reduced luminosity
- Solenoidal field $B = 1$ T
- BBC and ZDC for online polarimetry
- Micromegas central tracker
- Straw Tracker
150 m,
 $(\frac{dE}{dx}) = \pm 5\%$

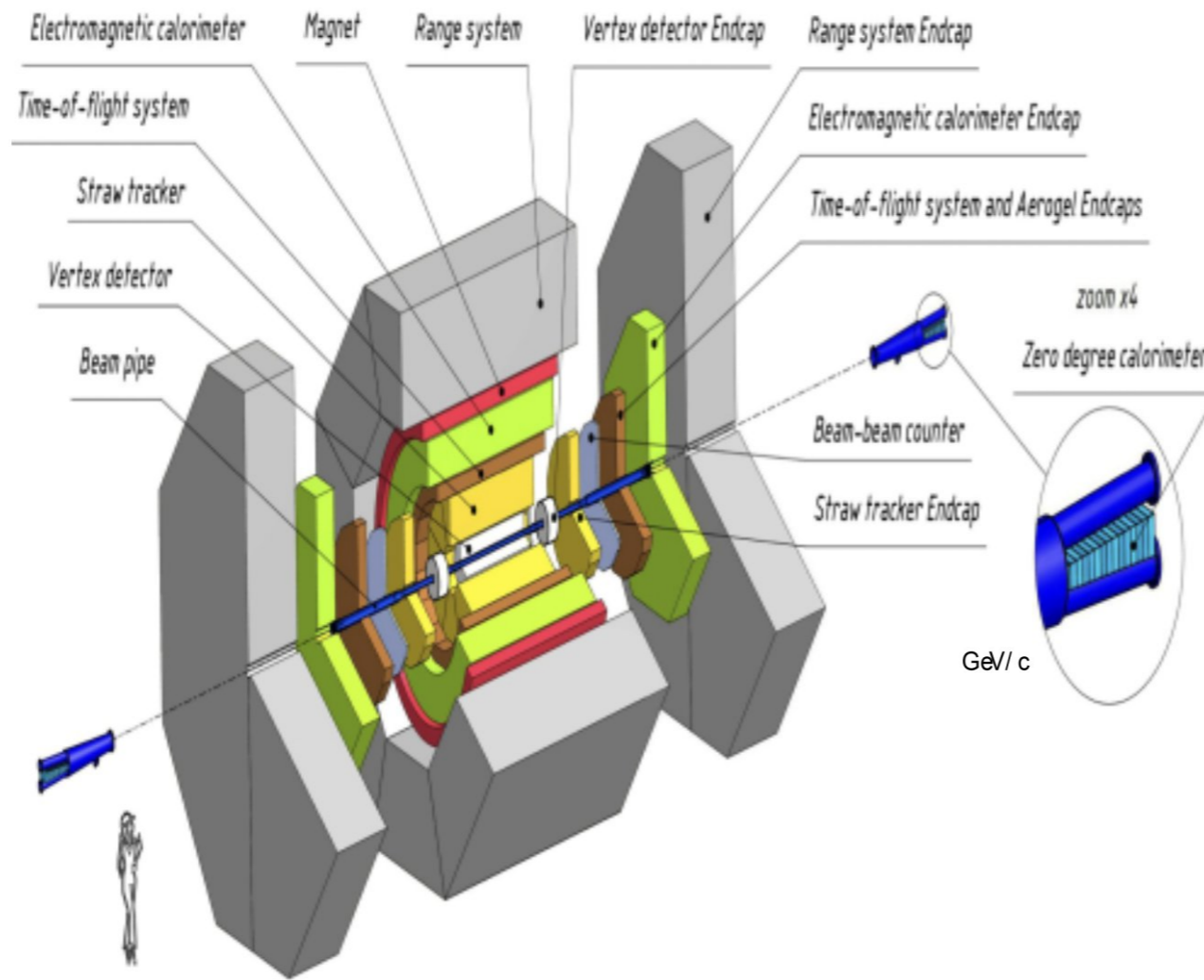

- Improved vertex detector for short lived particle decays
- TOF+A Gel for better PID
- ECAL for π , e identification

- Event rate at peak luminosity and energy 3M Hz
- Silicon vertex detector : MAPS/ DSSD
- Time of flight (TOF) for PID ($t \approx 50$ ps), π/K separation upto 1.5 GeV/ c
- Electromagnetic calorimeter (ECAL) ($\frac{\sigma_E}{E} = \frac{5\%}{\sqrt{E}} + 1\%$)
- Aerogel counter in endcaps, extends π/K separation upto 2.5 GeV/ c

SPD detector data flow

No hardware trigger at the SPD detector to avoid a possible bias:

3 MHz event/s at 10^{32} cm²/s design luminosity

20 GB/s \Rightarrow $3 \cdot 10^3$ events/year \Rightarrow 200 PB/year

**The SPD setup is a medium scale detector in size,
but a large scale one in data rate!**

Comparable in data rate with ATLAS and CMS at LHC

SPD Tier-1 Prototype Facilities:

- **NRC KI - PNPI, Gatchina**
- **SSU, Samara**

Towards SPD GRID

SPD Grid Sites:

- **LIT JINR**
- **NRC KI – PNPI, Gatchina**
- **SSU, Samara**

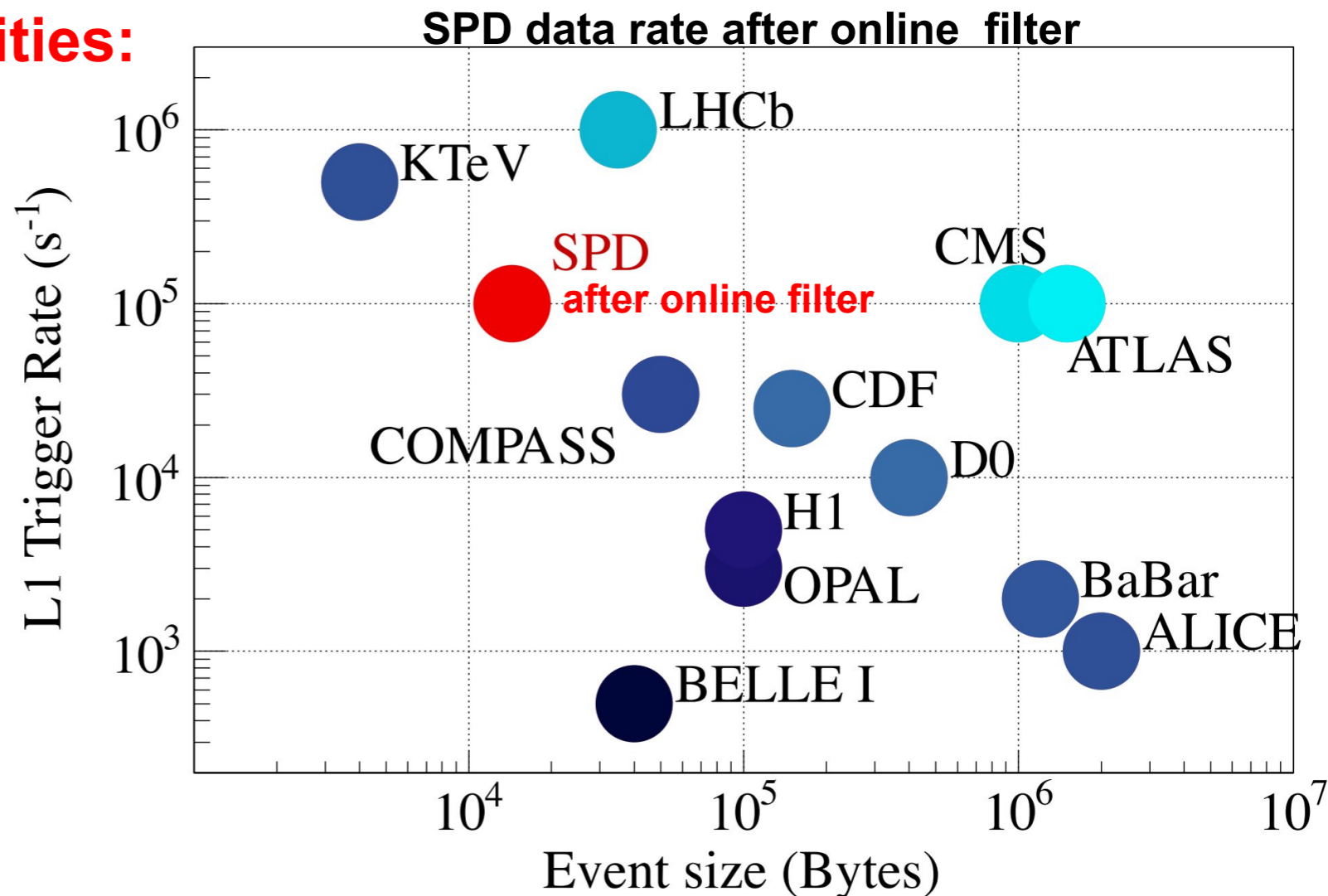

Considerations of SPD Tier-1 for the SPD 2nd Stage at NRC KI – PNPI, Gatchina

Computing resources	Distribution by year				
	1 st year	2 nd year	3 rd year	4 th year	5 th year
Data storage (TB) - EOS - Tapes	1500 0	2000 2000	5000 10000	7000 14000	10000 20000
Tier 1 (CPU corehours)	17 520 000	43 800 000	87 600 000	131 140 000	175 200 000
Tier 2 (CPU corehours)	1 752 000	4 380 000	8 760 000	13 114 000	17 520 000
SC Govorun (CPU core hours)	1 752 000	4 380 000	8 760 000	8 760 000	8 760 000

Towards SPD GRID:

- LIT JINR
- NRC KI – PNPI, Gatchina (Sep 2021)
- SSU, Samara (Aug 2025)

2007 Idea of SPD project is included to NICA activities at JINR

2014 SPD Letter of Intent is approved by JINR PAC

2016, 2018 SPD-oriented workshops in Prague

2019 SPD project is approved by JINR PAC (up to 2022)
The 1st SPD proto-Collaboration meeting

2020 Completion of SPD Conceptual Design Report (CDR)
<http://arxiv.org/abs/2102.00442>

2021 SPD Collaboration is established
Two SPD-physics papers were published

2024 SPD Technical Design Report (TDR): <http://spd.jinr.ru>
approved by JINR PAC June 2024
Natural Science Review (Dec. 2014) v. 1, p. 1

the SPD 1st Stage: included to the JINR 7-year Plan 2024-2030



Spin Physics
Detector



The NICA-SPD Collaboration, July 2021



40 organizations from 15 countries

> 400 participants

Signed MoU (16):

NRC “Kurchatov Institute” - PNPI, Gatchina
Alikhanov National Science Laboratory (Yerevan Physics Institute), Yerevan
Samara National Research University, Samara
Peter the Great Saint Petersburg Polytechnic University, St. Petersburg
Saint Petersburg State University, St. Petersburg
Skobeltsyn Institute of Nuclear Physics, Moscow State University, Moscow
Lebedev Institute of Physics RAS, Moscow
Institute for Nuclear Research RAS, Moscow
Institute of Nuclear Physics (INP RK), Almaty
Tomsk State University, Tomsk
National Research Nuclear University MEPhI, Moscow
Belgorod State University, Belgorod
Institute of Nuclear Problems, Belorussian State University, Minsk
Budker Institute of Nuclear Physics RAS, Novosibirsk
Higher Institute of Technologies and Applied Sciences, Havana
Higher School of Economics, Moscow
in signing: I-Temba Labs (South Africa), Univ. Cairo (Egypt)
New member: Shandong Univ. (China)

SPD Co-Spokespersons:

A.V. Guskov (JINR) & V.T. Kim (NRC KI - PNPI)

CB Chair: A. Tumasyan (AANL, Yerevan)

SPD Collaboration Meetings:

prior 2023: Dubna

2023: Dubna (April)
Samara (October)

2024: Almaty (May)
Dubna (November)

2025: Yerevan (May)
Dubna (October)

2026: Tomsk (May)
Dubna (October?)

SPD Collaboration Meeting: Yerevan 12-16 May 2025



9th SPD Collaboration Meeting

A. Alikhanyan National Laboratory (AANL – ErPhI)

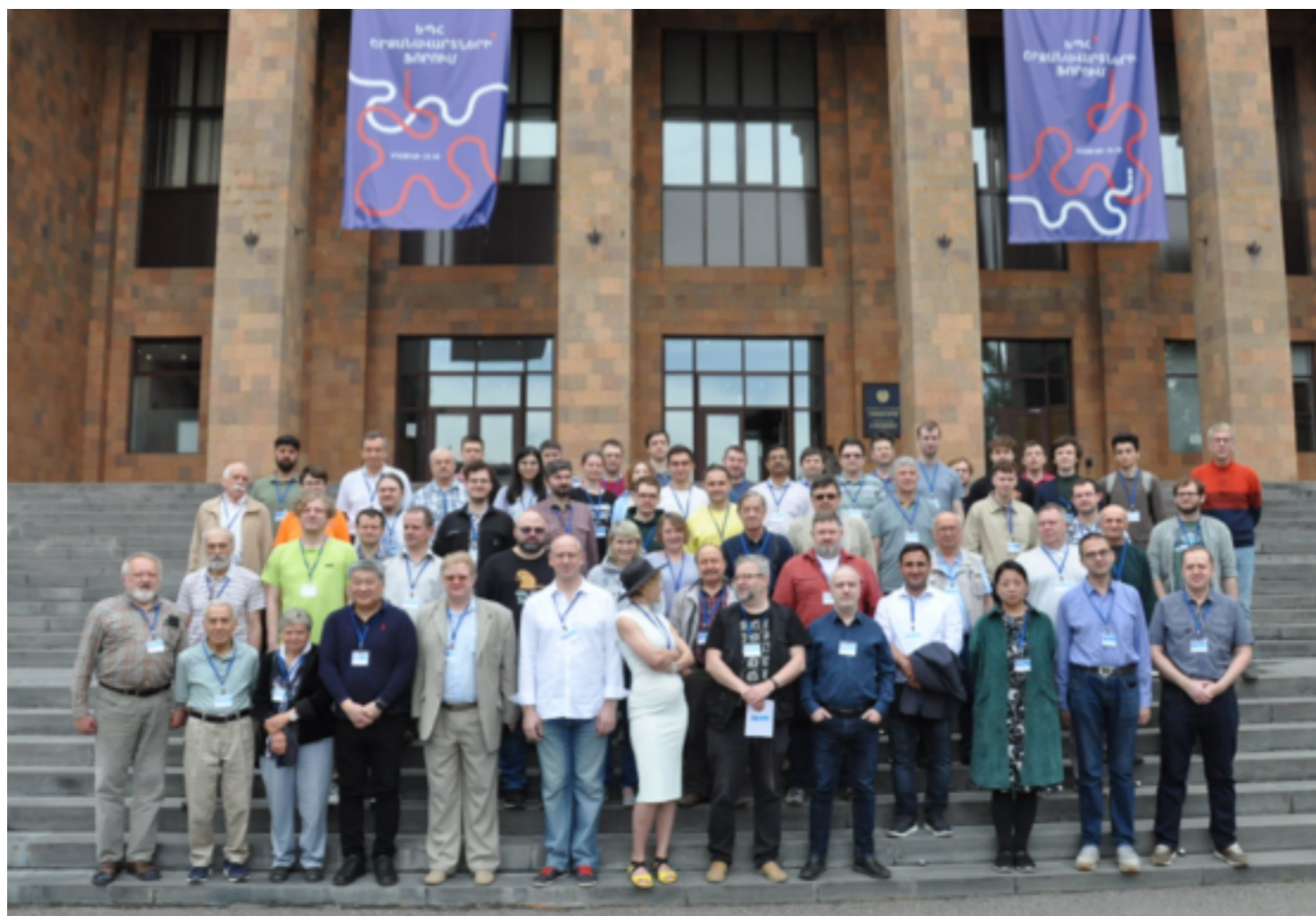

In person:

- > 60 participants*
- 13 organizations*
- 6 countries*



- ▶ **Spin Physics Detector (SPD) at NICA** (<http://spd.jinr.ru>):
a universal setup for comprehensive study of
polarized and unpolarized gluon content of proton and deuteron
in polarized and unpolarized high-luminosity pp- and dd- collisions at $\sqrt{s} \leq 27$ GeV
- ▶ **Complementing main probes: charmonia (J/Psi, higher states),**
open charm and direct photons in inclusive and semi-inclusive modes
- ▶ **SPD can reveal significant insights on:**
 - **gluon helicity structure**
 - **unpolarized gluon PDF at high x in proton and deuteron**
 - **gluon transversity in deuteron**
- ▶ **Comprehensive physics program for the initial period of data taking**
(can be performed even at reduced energy and luminosity)

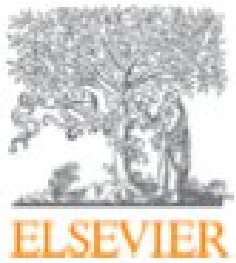

Progress in Particle and Nuclear Physics

Volume 119, July 2021, 103858



Review

ArXiv e-Print: [2011.15005](https://arxiv.org/abs/2011.15005) [hep-ex]

On the physics potential to study the gluon content of proton and deuteron at NICA SPD

A. Arbutov^a, A. Bacchetta^{b, c}, M. Butenschoen^d, F.G. Celiberto^{b, c, e, f}, U. D'Alesio^{g, h}, M. Deka^a, I. Denisenko^a, M.G. Echevarriaⁱ, A. Efremov^a, N.Ya. Ivanov^{a, j}, A. Guskov^{a, k, l, m, n}, A. Karpishkov^{l, a}, Ya. Klopot^{a, m}, B.A. Kniehl^d, A. Kotzinian^{j, o}, S. Kumano^p, J.P. Lansberg^q, Keh-Fei Liu^r, F. Murgia^h, M. Nefedov^l, B. Parsamyan^{a, n, o}, C. Pisano^g, M. Radici^c, A. Rymbekova^a, V. Saleev^{l, a}, A. Shipilova^{l, a}, Qin-Tao Song^s, O. Teryaev^a

Possible studies at the first stage of the NICA collider operation with polarized and unpolarized proton and deuteron beams

Phys. Part. Nucl. Vol.52, 2021, 1044

ArXiv e-Print: [2102.08477](https://arxiv.org/abs/2102.08477) [hep-ph]

V. V. Abramov¹, A. Aleshko², V. A. Baskov³, E. Boos², V. Bunichev², O. D. Dalkarov³, R. El-Kholy⁴, A. Galoyan⁵, A. V. Guskov⁶, V. T. Kim^{7, †}, E. Kokoulina^{5, ‡}, I. A. Koop^{10, 11, 12}, B. F. Kostenko¹³, A. D. Kovalenko⁵, V. P. Ladygin⁵, A. B. Larionov^{14, 15}, A. I. Lvov³, A. I. Milstein^{10, 11}, V. A. Nikitin⁵, N. N. Nikolaev^{16, 26}, A. S. Popov¹⁰, V. V. Polyanskiy³, J.-M. Richard¹⁷, S. G. Salnikov¹⁰, A. A. Shavrin^{7, 1†}, P. Yu. Shatunov^{10, 11}, Yu. M. Shatunov^{10, 11}, O. V. Selyugin¹⁴, M. Strikman^{1‡}, E. Tomasi-Gustafsson²⁰, V. V. Uzhinsky¹³, Yu. N. Uzikov^{6, 21, 22, *}, Qian Wang²³, Qiang Zhao^{24, 25}, A. V. Zelenov⁷

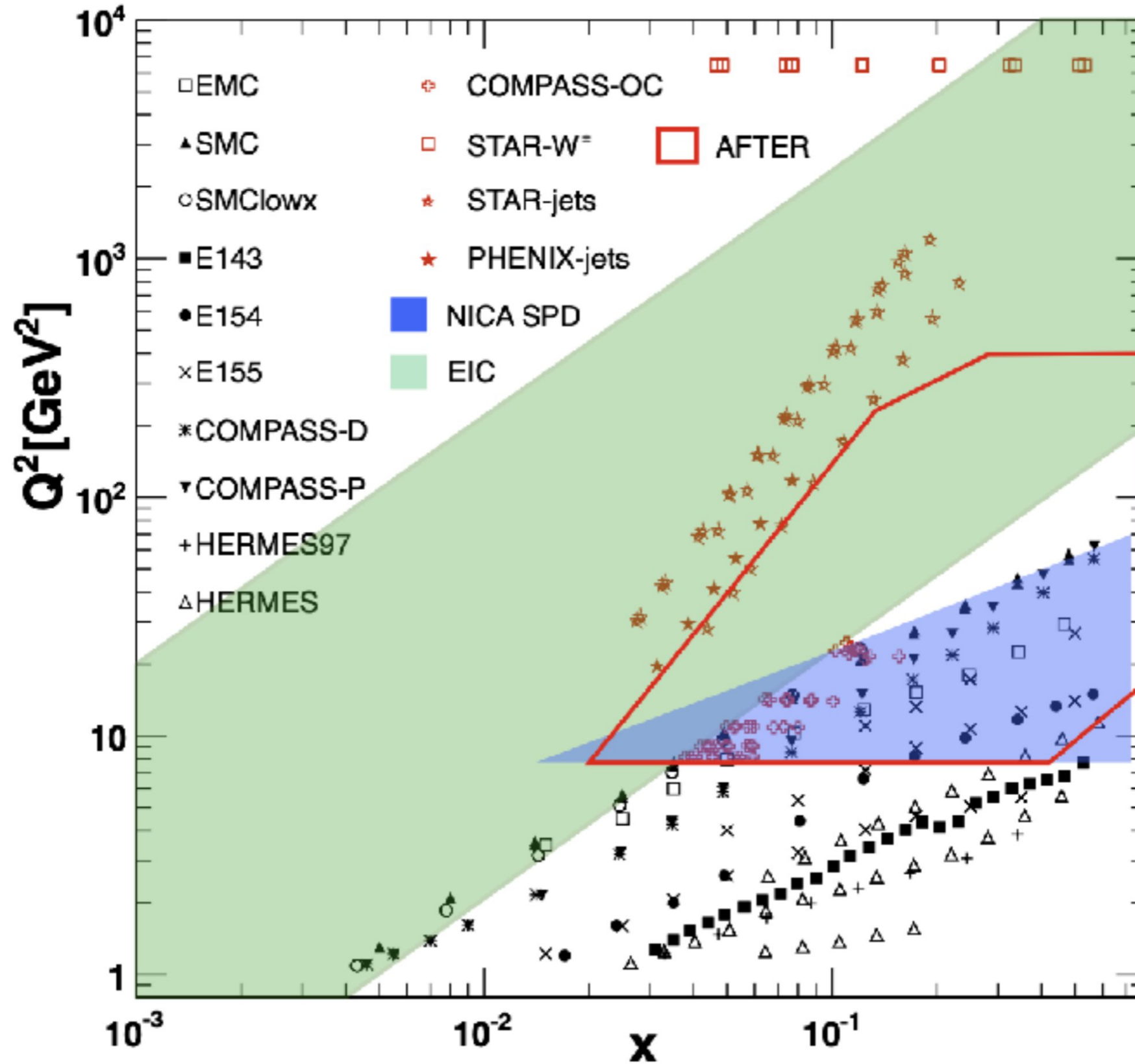

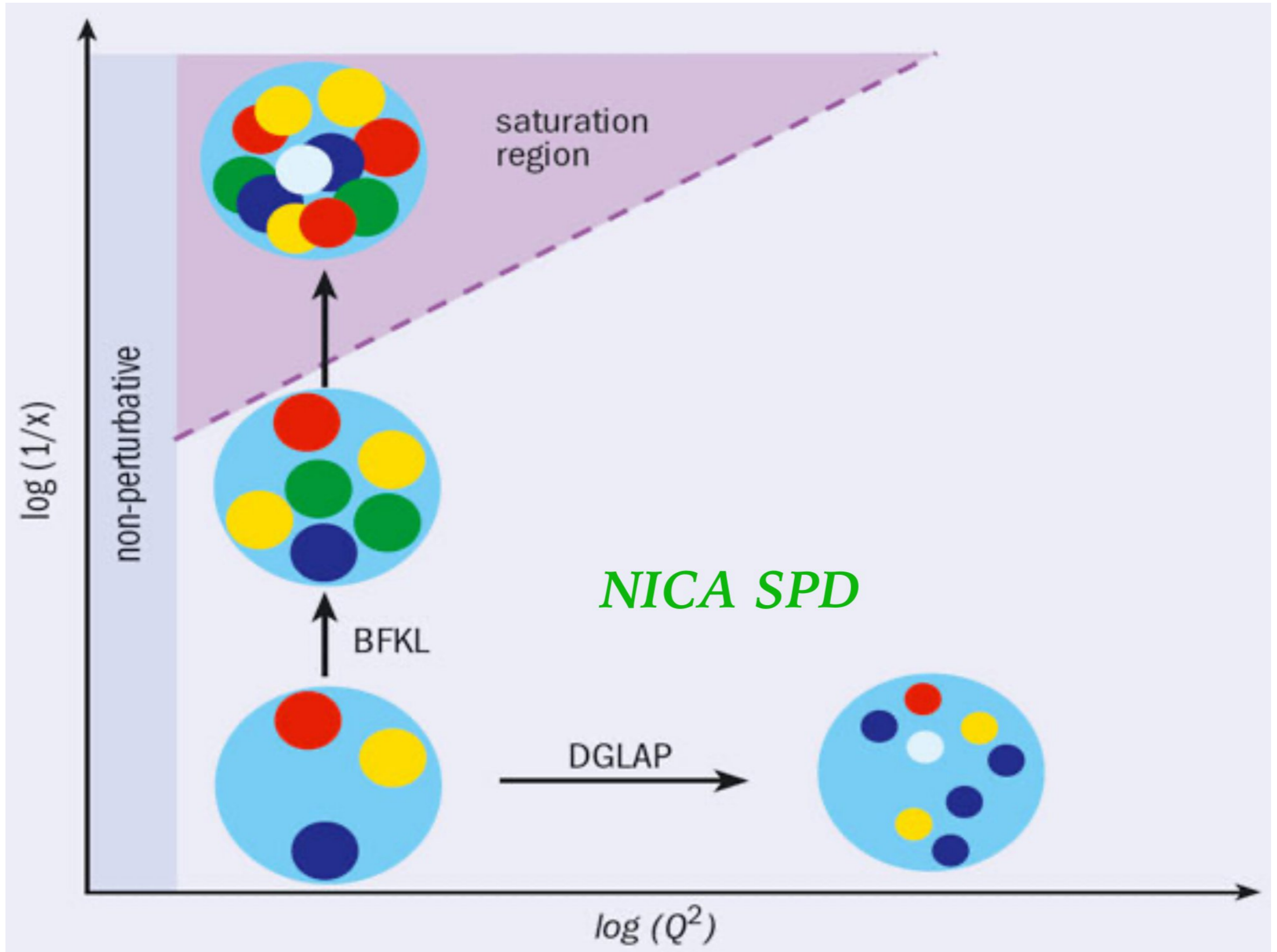

Gluon probes at SPD: charmonia, open charm, direct photons

not only J/ψ !

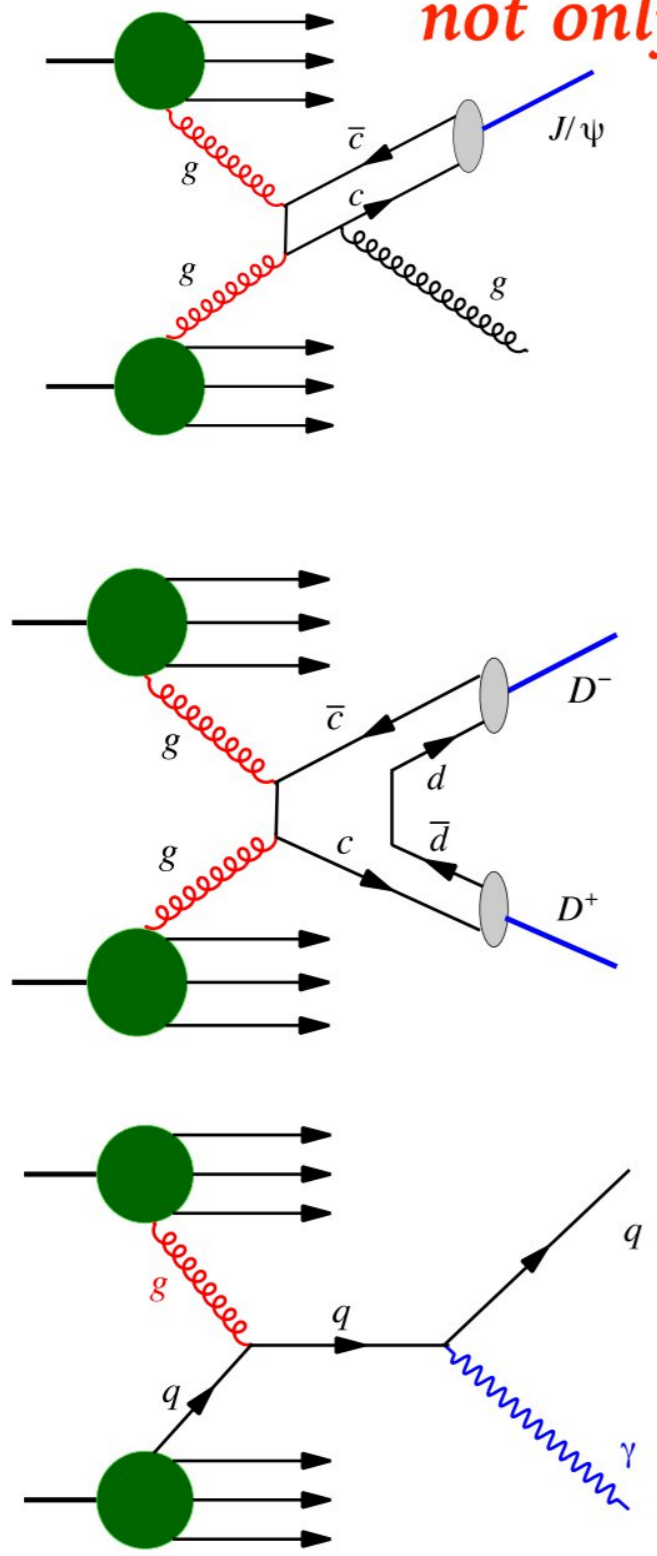

$$\sigma = PDF_1 \otimes PDF_2 \otimes \hat{\sigma}_{12}$$

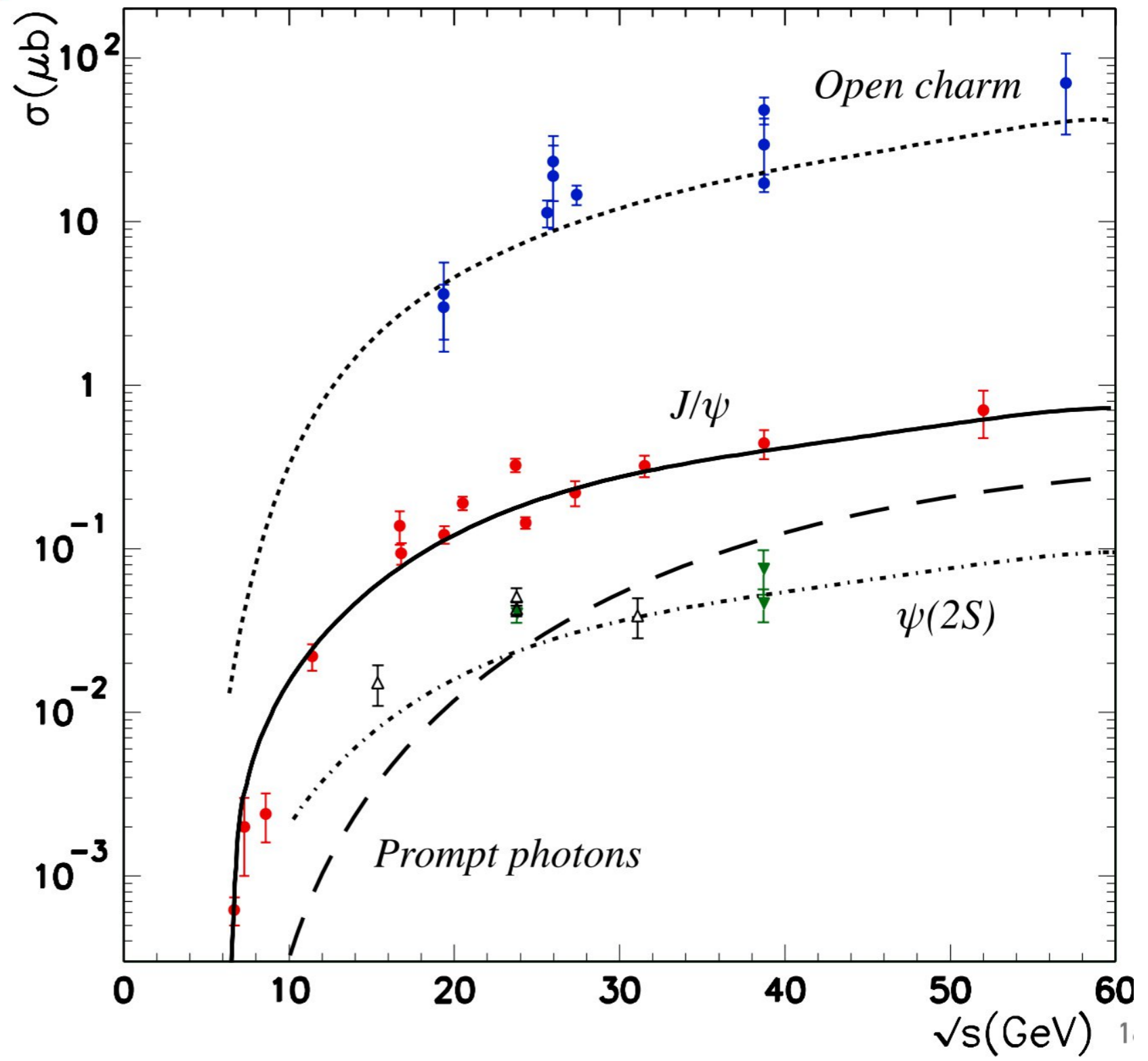

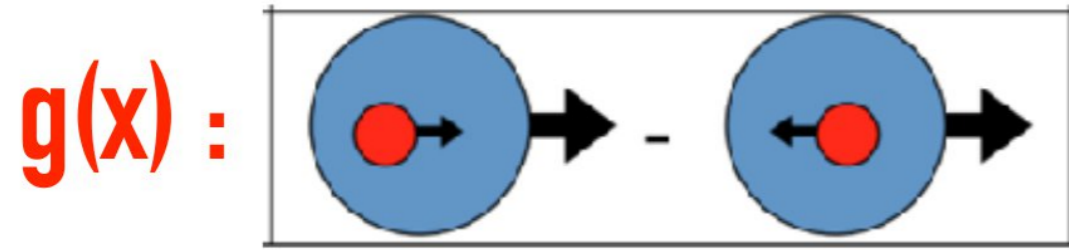

$$\Delta G = \int_0^1 \Delta g(x) dx$$

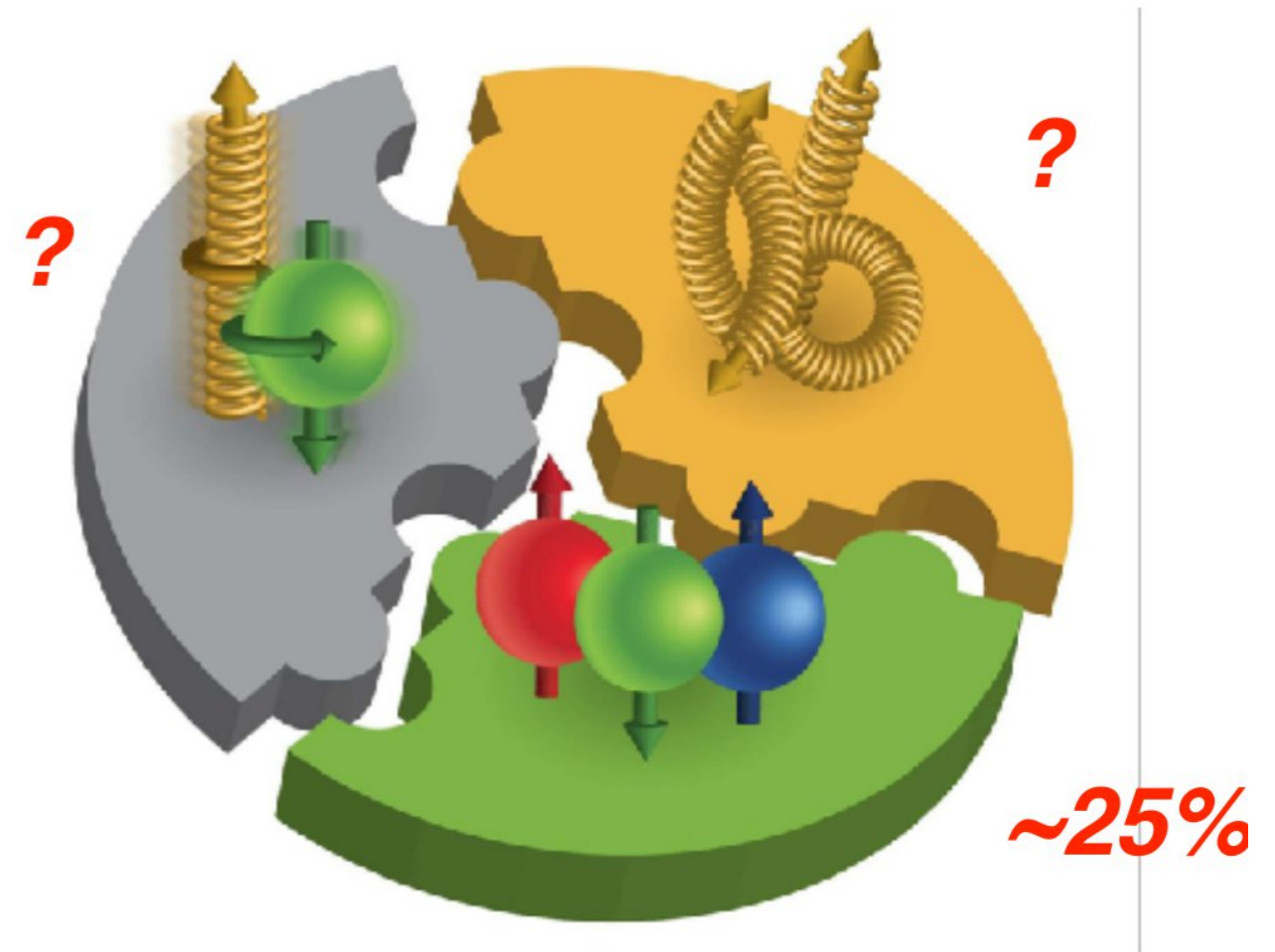
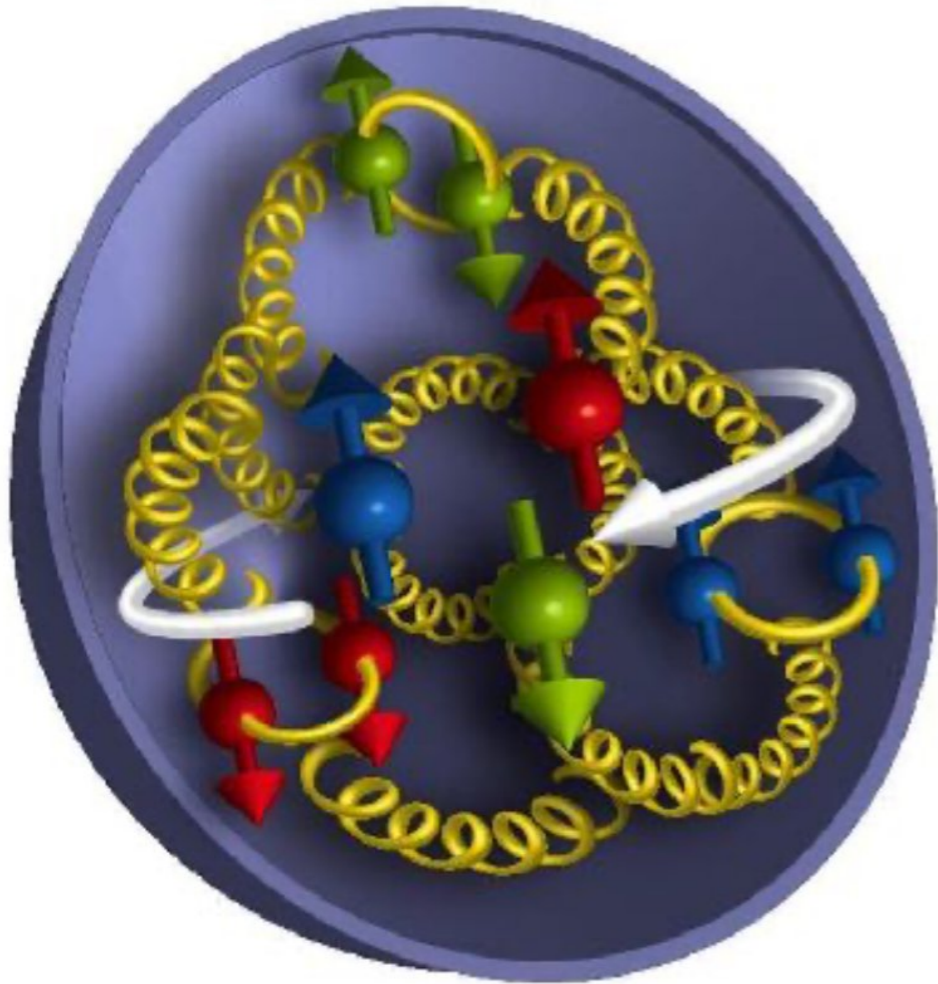

$$S_N = \frac{1}{2} = \frac{1}{2} \Delta \Sigma + \Delta G + L$$

NNPDF Coll.: quark and gluon helicity PDFs of proton

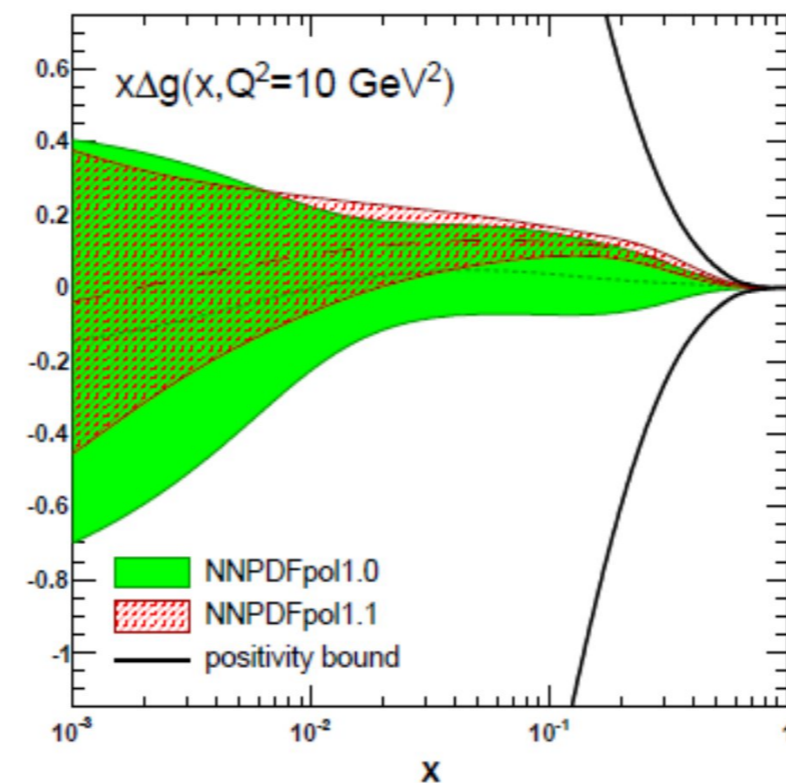
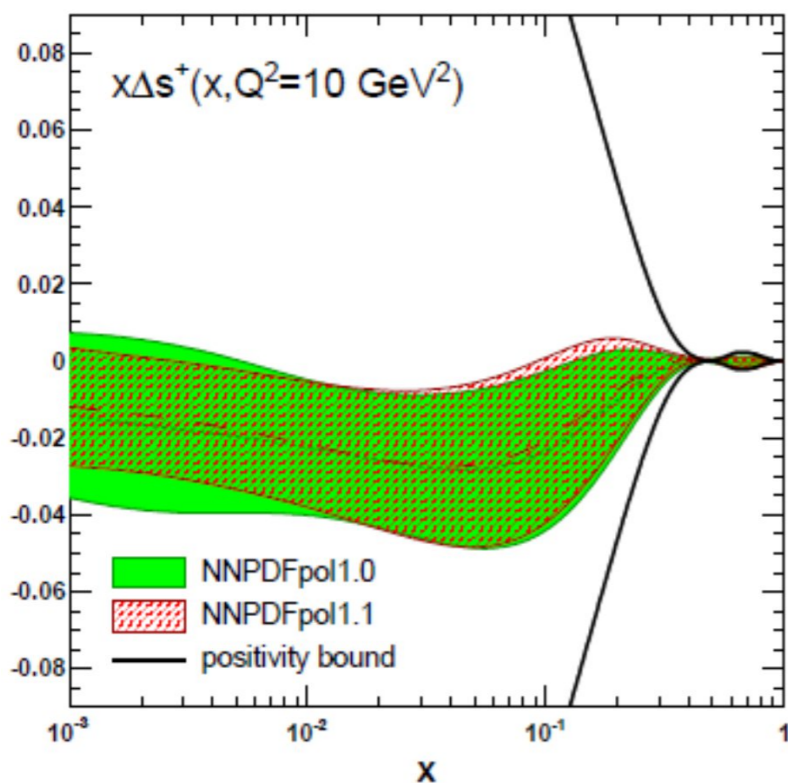
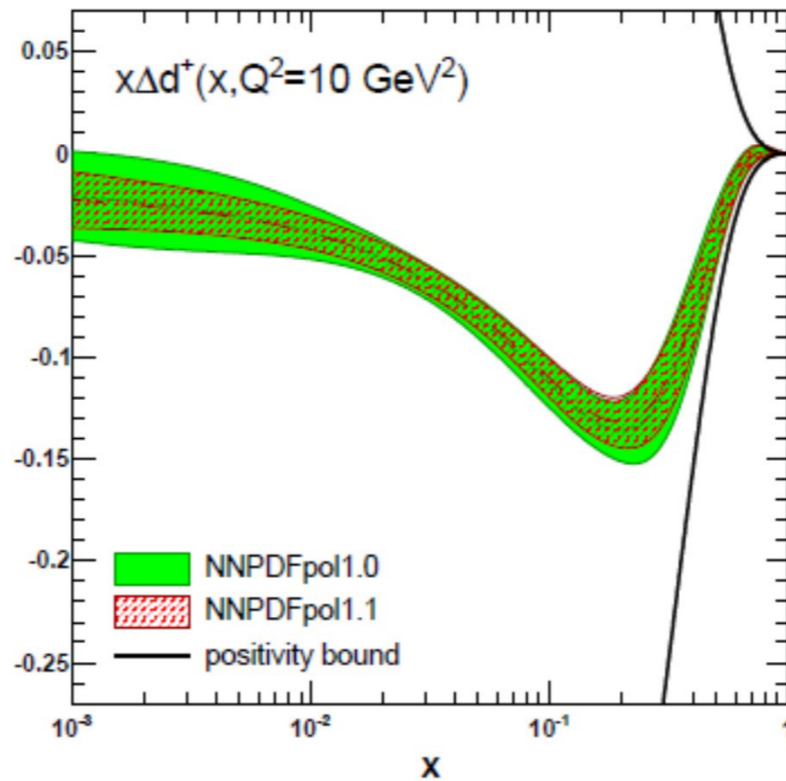
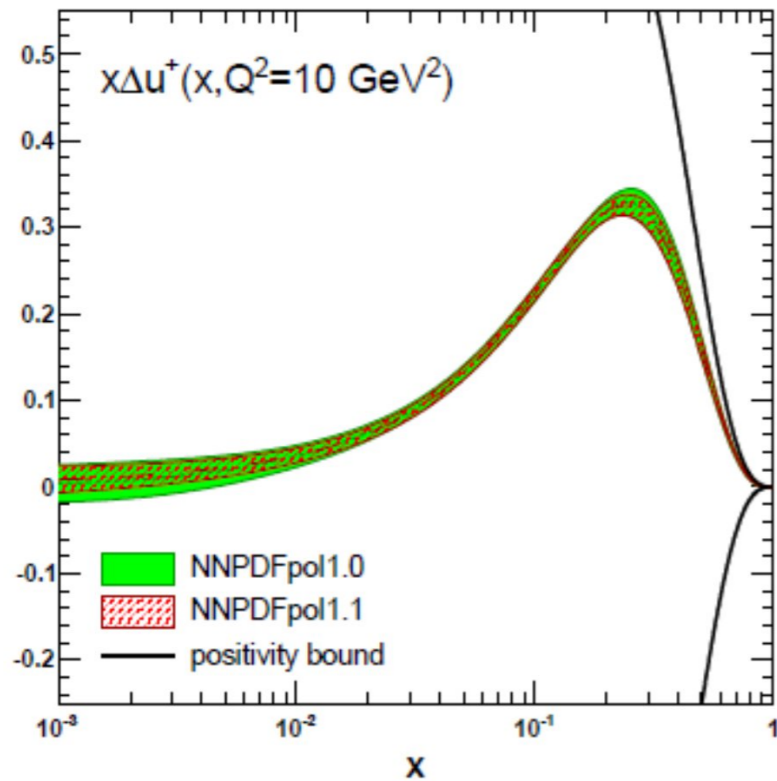

NNPDF Coll.:
E. Nocera et al. (2014)

Quark helicity PDF:
few percent level uncertainties

It is measured with
high precision in DIS

Gluon helicity PDF:
still rather high uncertainties!

Hadron collisions have a better
sensitivity to measure it.

← SPD has a good opportunity!

accessible with SPD

Phys.Rev.Lett. 113 (2014) 1, 012001

EIC

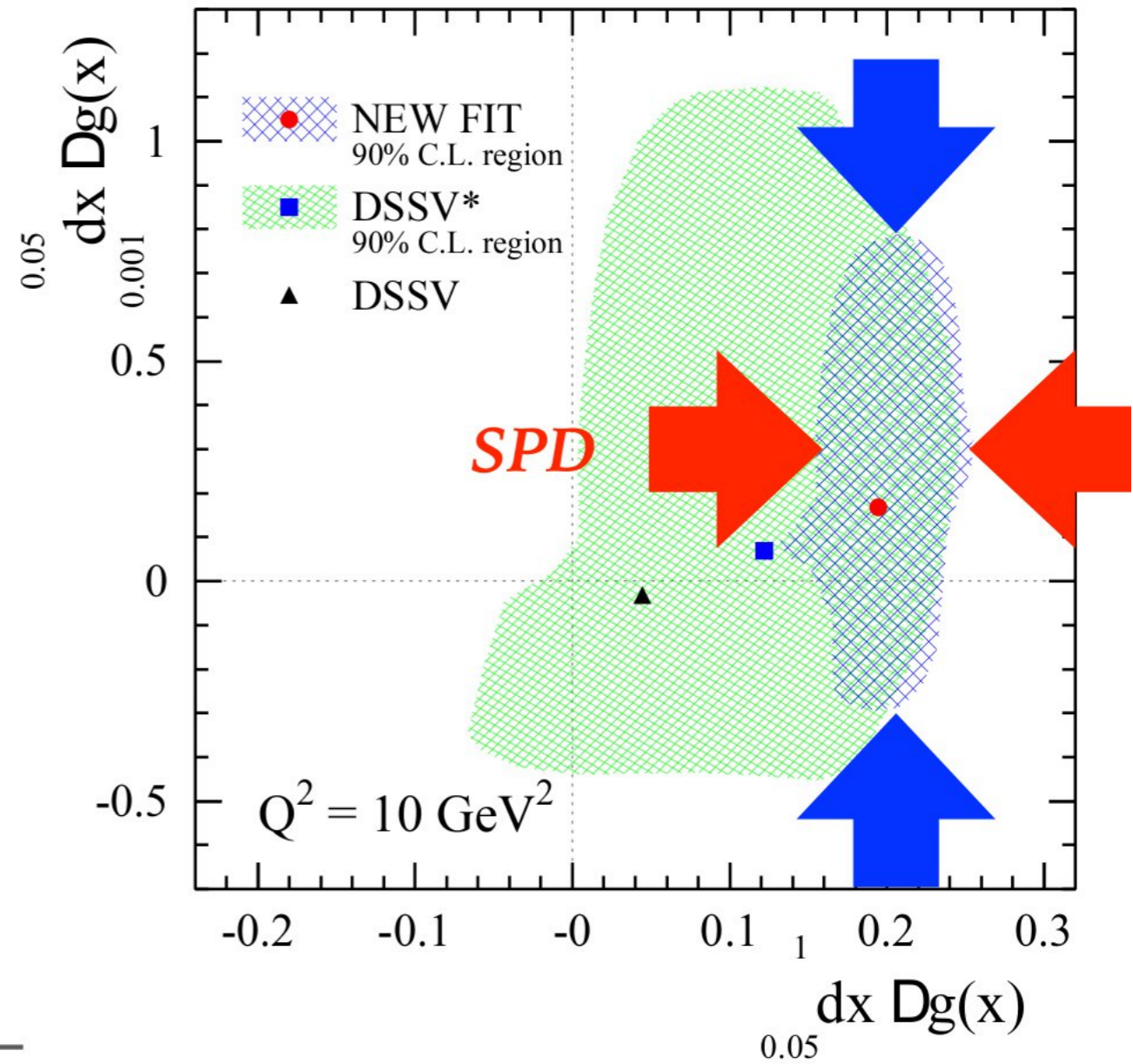
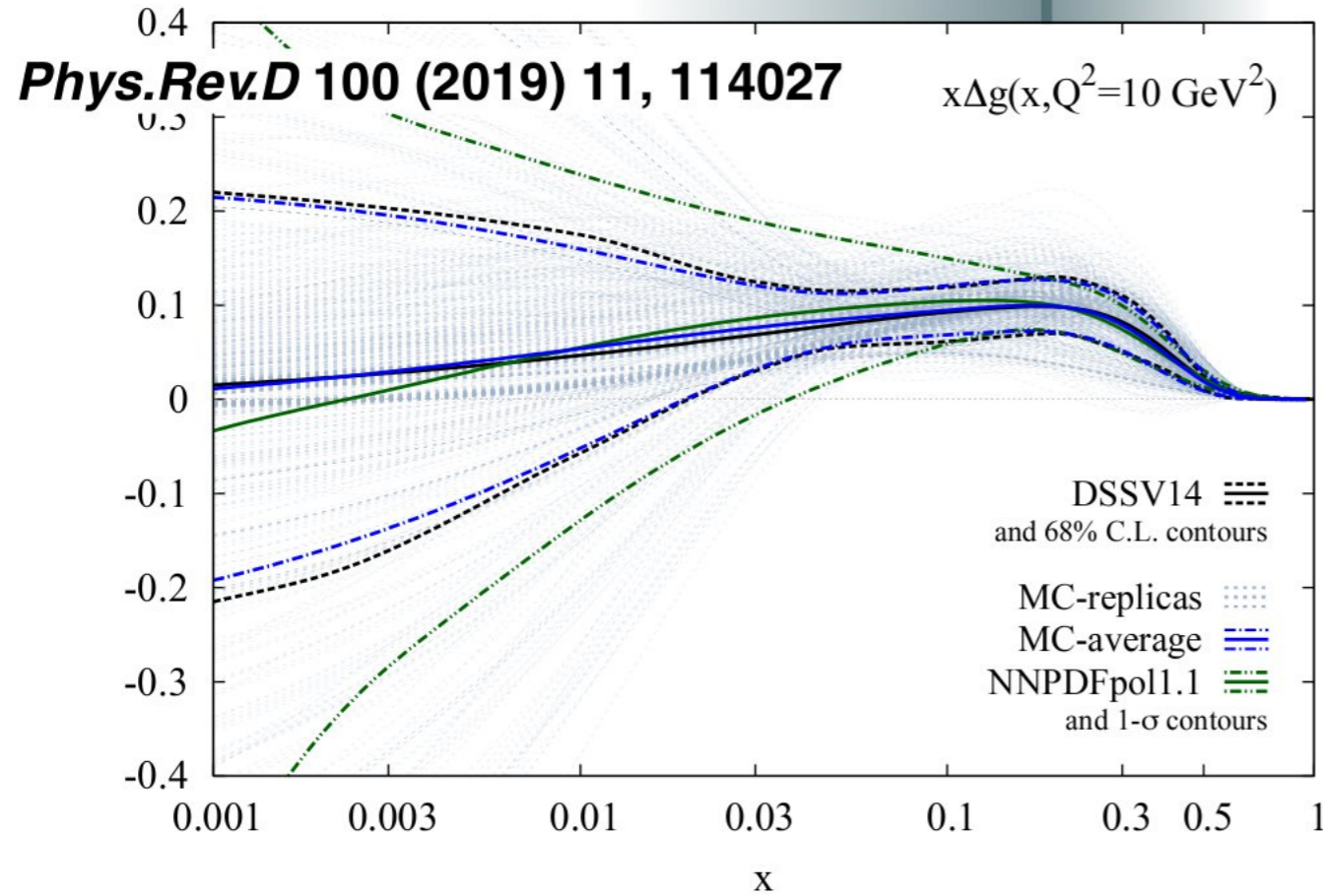

SPD could help to reduce uncertainty of G at large x

$$A_{LL} = \frac{\sigma^{++} \sigma^+}{\sigma^{++} + \sigma^+}$$

$$A_{LL}^{cc} \approx \frac{\Delta g(x_1)}{g(x_1)} \otimes \frac{\Delta g(x_2)}{g(x_2)} \otimes \hat{a}_{LL}^{gg \rightarrow ccX} \quad A_{LL}^{\gamma} \approx \frac{\Delta g(x_1)}{g(x_1)} \otimes A_{1p}(x_2) \otimes \hat{a}_{LL}^{gq(q) \rightarrow \gamma q(q)} + (1 \leftrightarrow 2).$$

Spin of proton

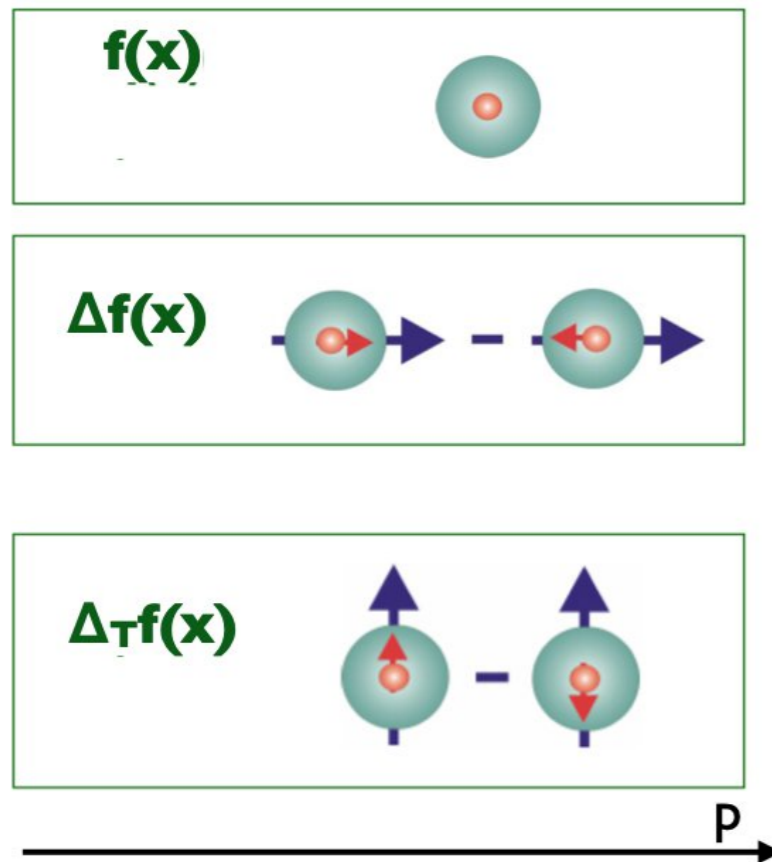

Unpolarized PDF

Helicity

Transversity

$$J = \frac{1}{2} \Delta\Sigma \sim 30\% + \Delta G \sim 10-20\% + L_q + L_g$$

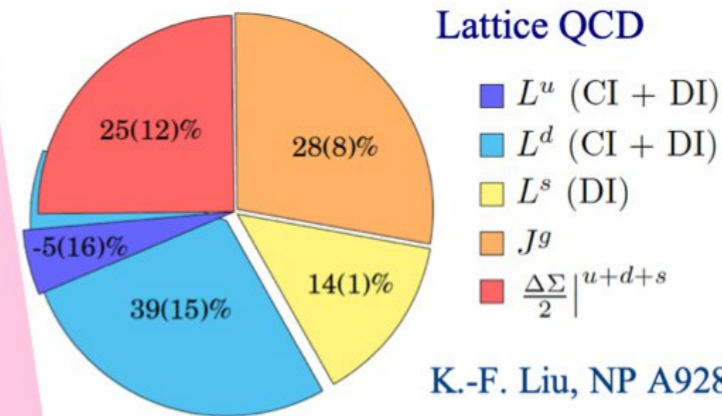

K.-F. Liu, NP A928, 99 (2014).

To access angular momenta info about 3D structure is needed!

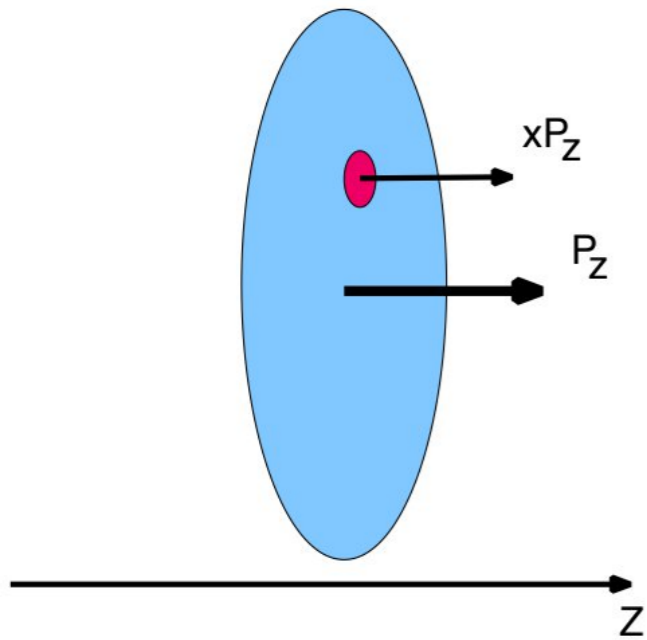

*Collinear approximation
(common PDF)*

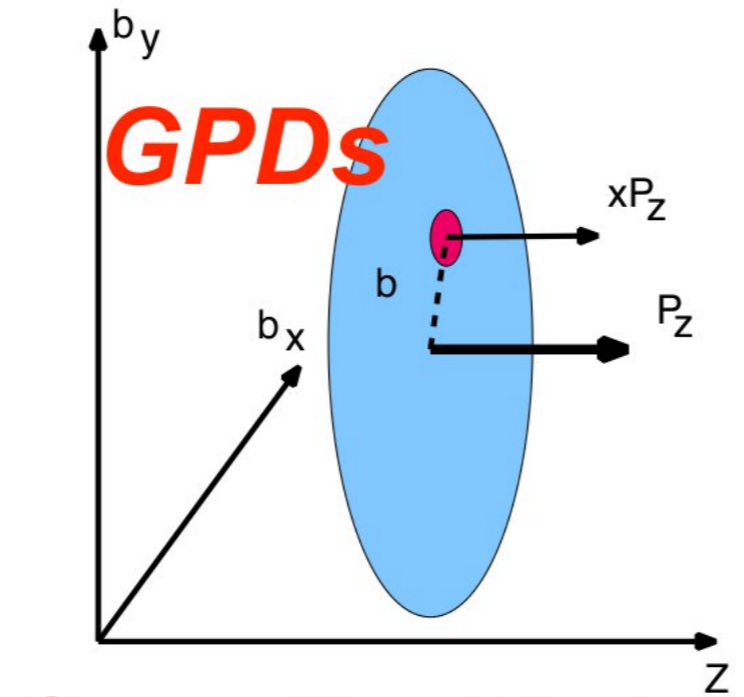

Generalized Parton Distributions

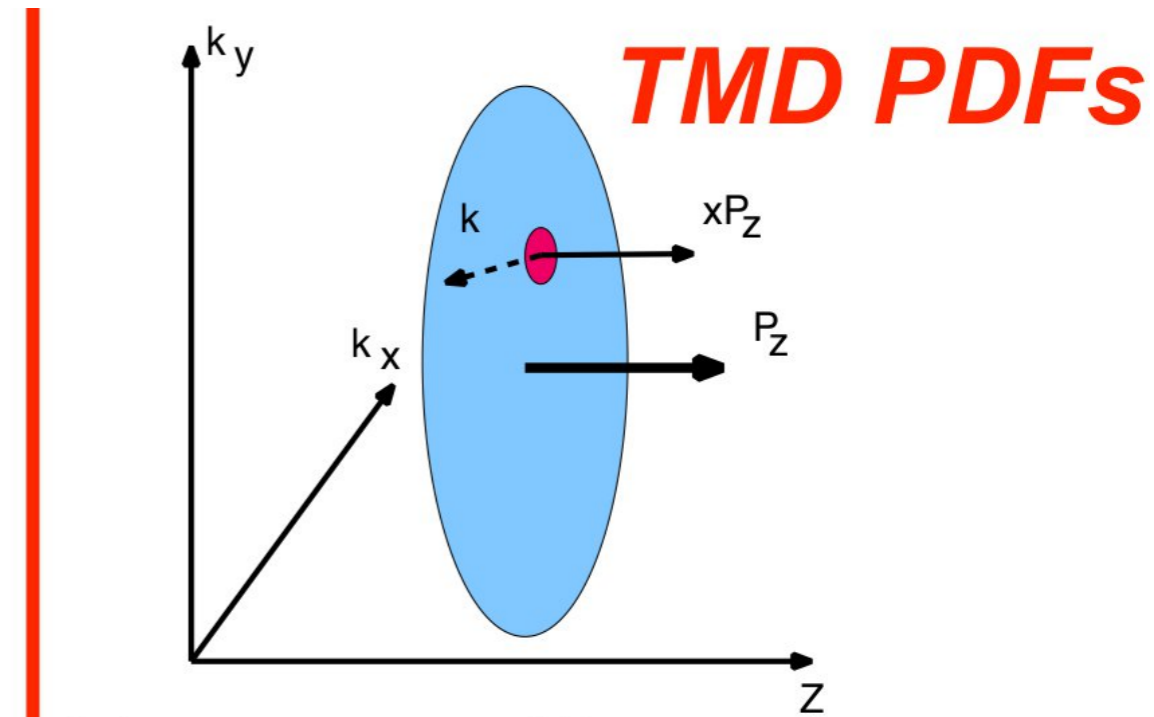

Transverse Momentum Dependent PDFs

3D structure of nucleon

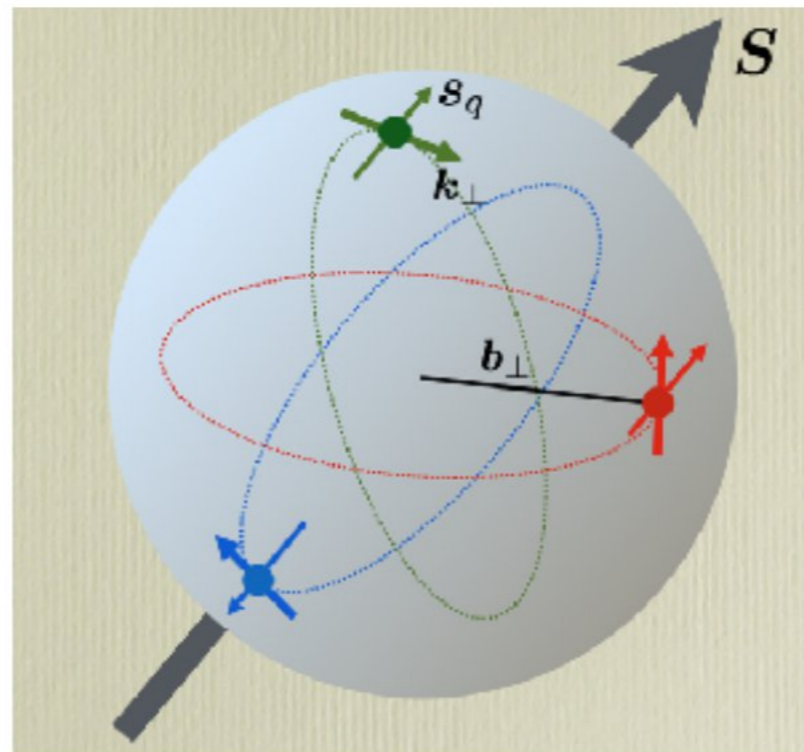

connection to orbital moment

Nucleon (N) with momentum P and spin polarization $S=(U,L,T)$

New information in quark TMD of nucleon: $\Phi^q(x, P, S)$

$\Phi^q(x, P, S)$ contains time-even functions:

$f^q(x, kT) \leftarrow$ unpolarized quarks in unpolarized N \leftarrow density

$g^q_L(x, kT) \leftarrow$ L-polarized (chiral) quarks in L-polarized N \leftarrow helicity

$g^q_T(x, kT) \leftarrow$ L-polarized (chiral) quarks in T-polarized N \leftarrow worm-gear

$h^q_T(x, kT) \leftarrow$ T-polarized quarks in T-polarized N \leftarrow pretzelosity

and time-odd functions (spin-orbital correlations):

$f^{\perp q}_L(x, kT) \leftarrow$ unpolarized quarks in T-polarized N \leftarrow Sivers f.

$h^{\perp q}_T(x, kT) \leftarrow$ T-polarized quarks in unpolarized N \leftarrow Boer-Mulders f.

Integrated over kT quark TMDs:

$$f^q(x) = q(x) = q_{L=+}(x) + q_{L=-}(x)$$

$$g^q_L(x) = \Delta q(x) = q_{L=+}(x) - q_{L=-}(x) \leftarrow \text{helicity (chirality)}$$

$$h^q_T(x) = \delta q(x) = q_{T=+}(x) - q_{T=-}(x) \leftarrow \text{transversity}$$

$N \backslash Q$	U	L	T	
U	f_1 number density 		h_1^\perp Boer-Mulders 	
L		g_1 helicity 	h_{1L}^\perp worm-gear 	
T	f_{1T}^\perp Sivers 	g_{1T}^\perp worm-gear 	h_1 transversity 	h_{1T}^\perp pretzelosity

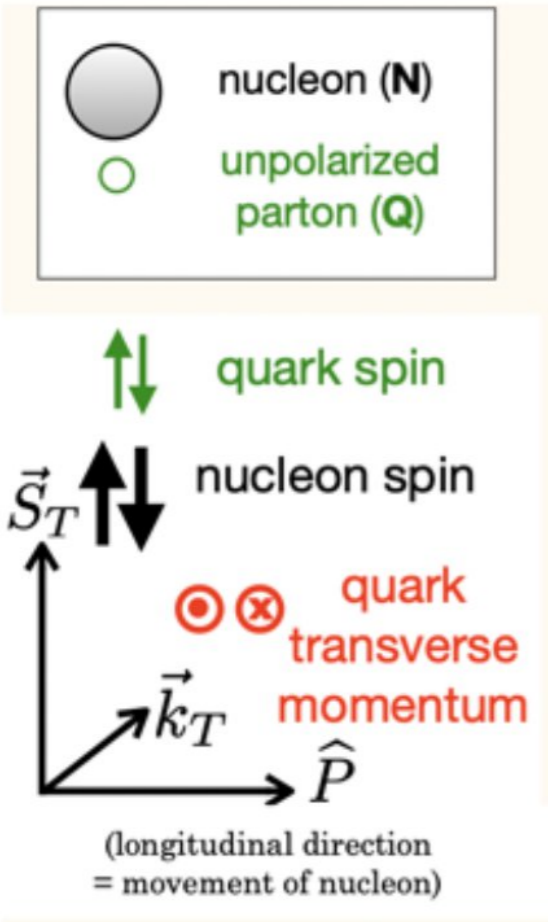

Unpolarized gluons at high x
in proton and deuteron

Gluon helicity

Gluon Boer-Mulders function

GLUONS	<i>unpolarized</i>	<i>circular</i>	<i>linear</i>
U	f_1^g		$h_1^{\perp g}$
L		g_{1L}^g	$h_{1L}^{\perp g}$
T	$f_{1T}^{\perp g}$	g_{1T}^g	$h_{1T}^g, h_{1T}^{\perp g}$

Gluon Sivers function

Gluon transversity in
deuteron

Unpolarized distribution functions

$$q = q_+^+ + q_-^+ \quad g = g_+^+ + g_-^+$$

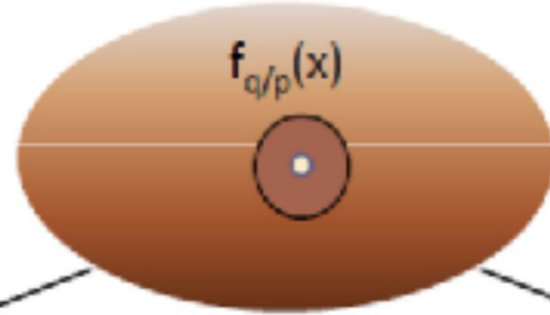

Transversity comes from spin-flip:
 $\Delta s=2$ forbidden for spin- $1/2$ nucleon in LO

→ gluon transversity in nucleon ≈ 0

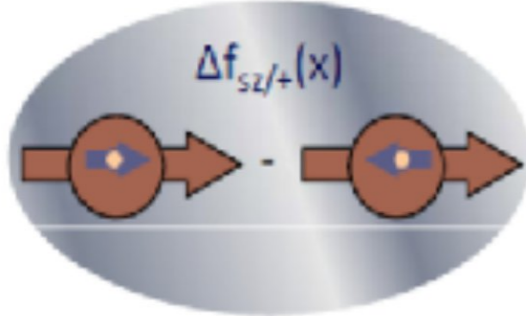

Helicity distribution functions

$$\Delta q = q_+^+ - q_-^+ \quad \Delta g = g_+^+ - g_-^+$$

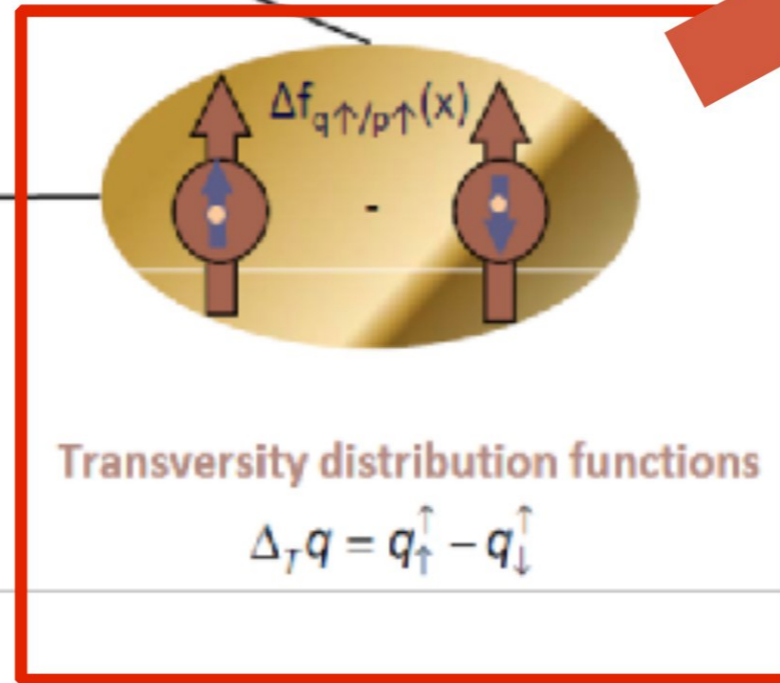

Transversity distribution functions

$$\Delta_T q = q_{\uparrow}^+ - q_{\downarrow}^+$$

SPD has a unique opportunity to measure gluon transversity in deuteron for the first time!

To probe new non-nucleonic degrees of freedom in deuteron!

0.

Lepton pairs S. Kumano

$$\Delta_T g(x) = \Delta g(x)$$

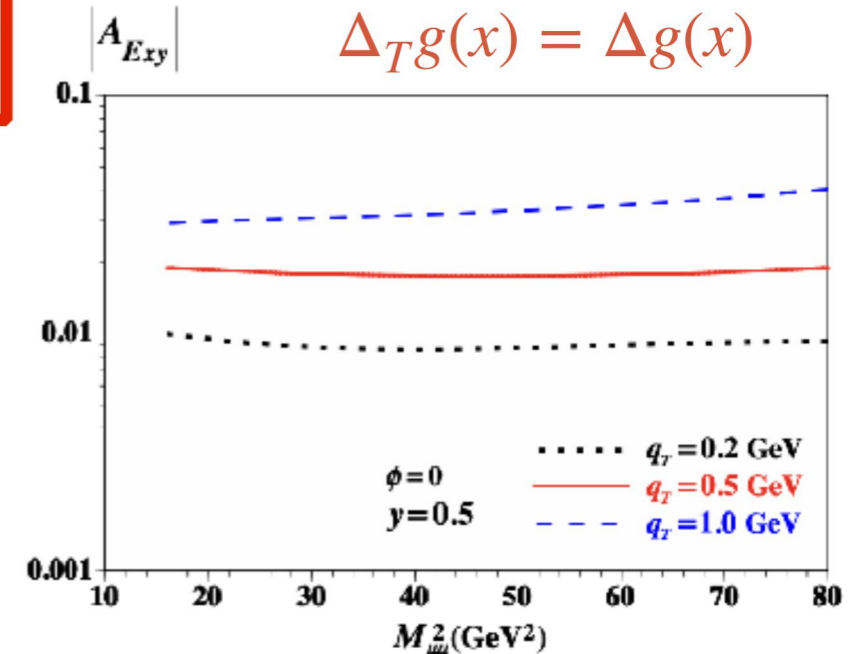

SPD Physics at the 1st Stage

V.V. Abramov et al., Phys. Part. Nucl. 52(2021) 1044, e-Print: [2102.08477](https://arxiv.org/abs/2102.08477) [hep-ph]

Comprehensive and rich physics program at the initial stage of SPD data taking:

- ▶ Spin effects in pp-, pd- and dd- (quasi)elastic scattering
- ▶ Spin effects in hyperon production
- ▶ Search for exotic states (glueball, penta- and tetra- quarks)
- ▶ Multiquark correlations (SRC) in deuteron and light nuclei
- ▶ Dibaryon resonances
- ▶ Hypernucleus production
- ▶ Open charm and charmonia production near threshold
- ▶ Large-pT hadron production to study diquark structure of proton
- ▶ Large-pT hadron production to study multiparton scattering
- ▶ Antiproton production measurement for astrophysics and BSM search
- ▶ ...

► 14 proposed measurements

> online 60 participants



23.04.2025 Zoom only

We invite you for the discussion of existing elaborated SPD proposals

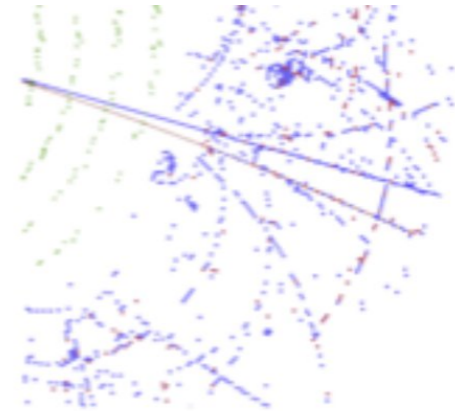

SPD first stage physics workshop
 брлзгс мокгроб

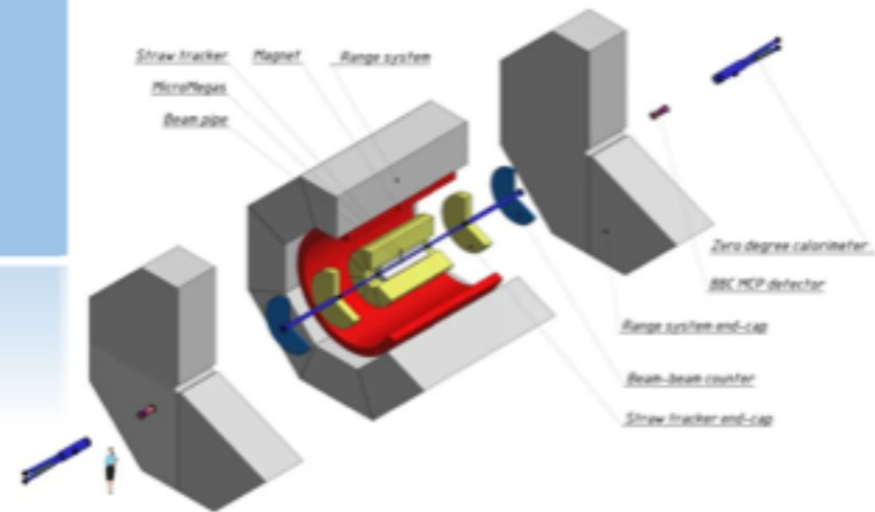

SPD Physics at the 1st Stage: exotic states pentaquark, dihyperon, tetraquark, etc. production

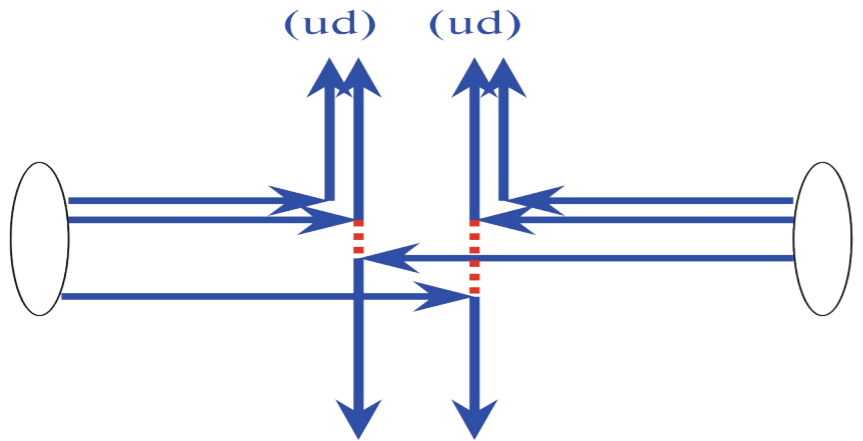

Diquarks:

- proton production scaling violation
V.K. 1988
- exotic multiquark state production
A. Efremov, V.K. 1987
V. Abramov et al 2021

Diquarks:

tetraquark production $a(980)?$: $\sim 5-10\%$ of large- p_T proton production
V.K., A.V. Zelenov 2025

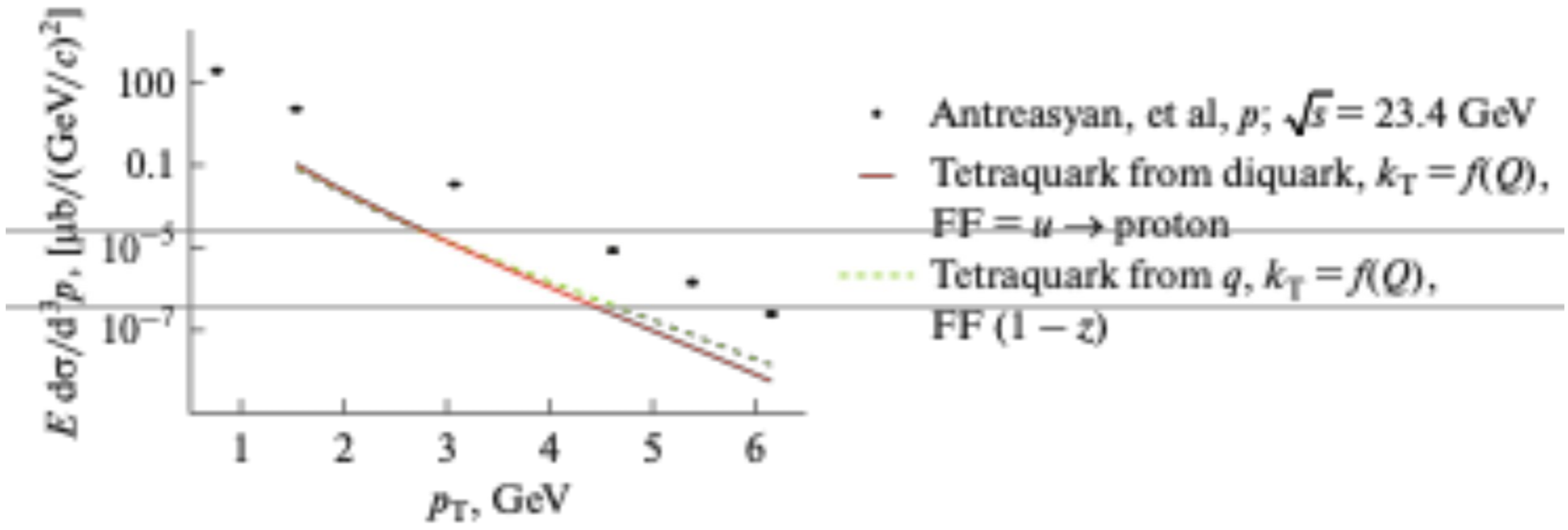

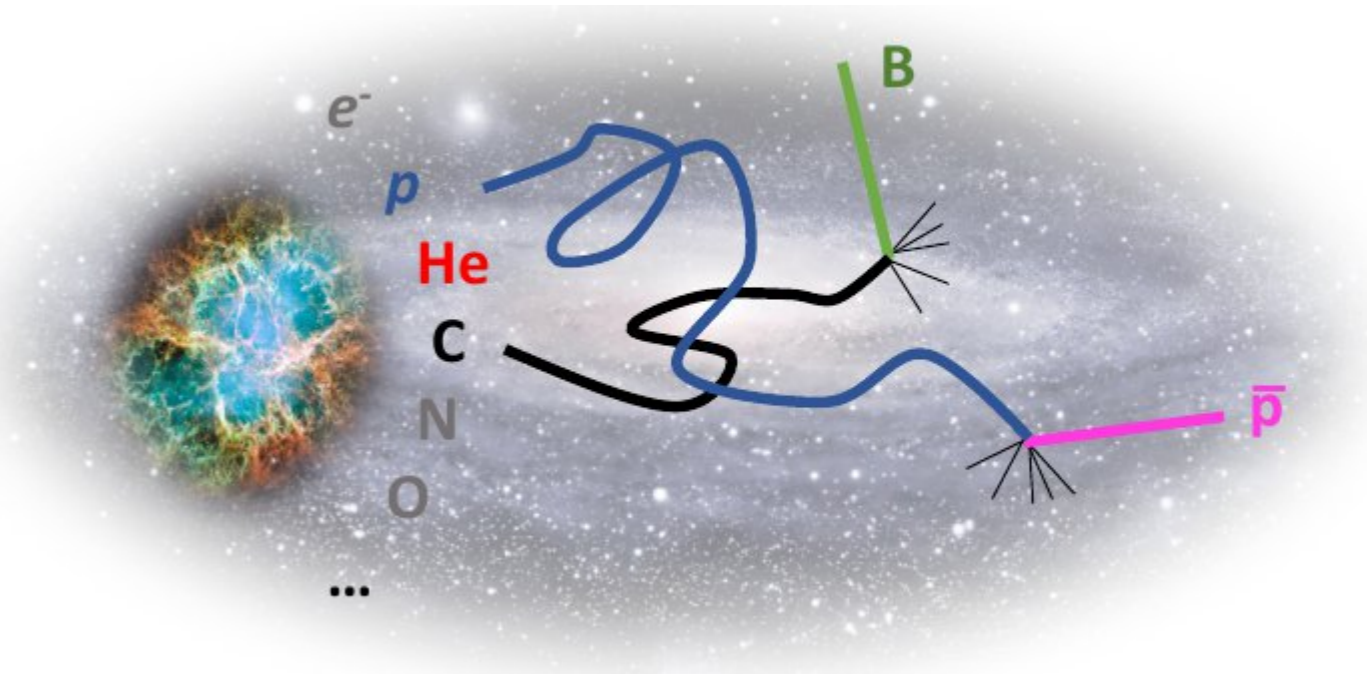

ASTROPHYSICS

AMS-02 in International Space Station

AMS-02 search for Dark Matter:
antiproton flux precision $\sim 5\%$

Contemporary high energy physics experiments
antiproton production $\sim 25\%$

Precision antiproton production measurements needed:
energy range $5 \text{ GeV} < \text{ECM} < 100 \text{ GeV}$ with precision $\sim 5\%$

- ▶ **Load-bearing structure of the Detector & Yoke**
- ▶ **Superconducting magnet (INP, Novosibirsk)**
- ▶ **Engineering infrastructure & communications**
- ▶ **The 1st Stage detectors: Trackers, Muon (RS), BBC, ZDC, part of ECAL -> to manufacture**
- ▶ **The 2nd Stage detectors: ToF, FARICH, Vertex detector -> R&D**
- ▶ **DAQ and computing infrastructure**
- ▶ **The 1st Stage Physics program -> Updating**
- ▶ **SPD Interaction Point at NICA -> BBC and ZDC are installed**

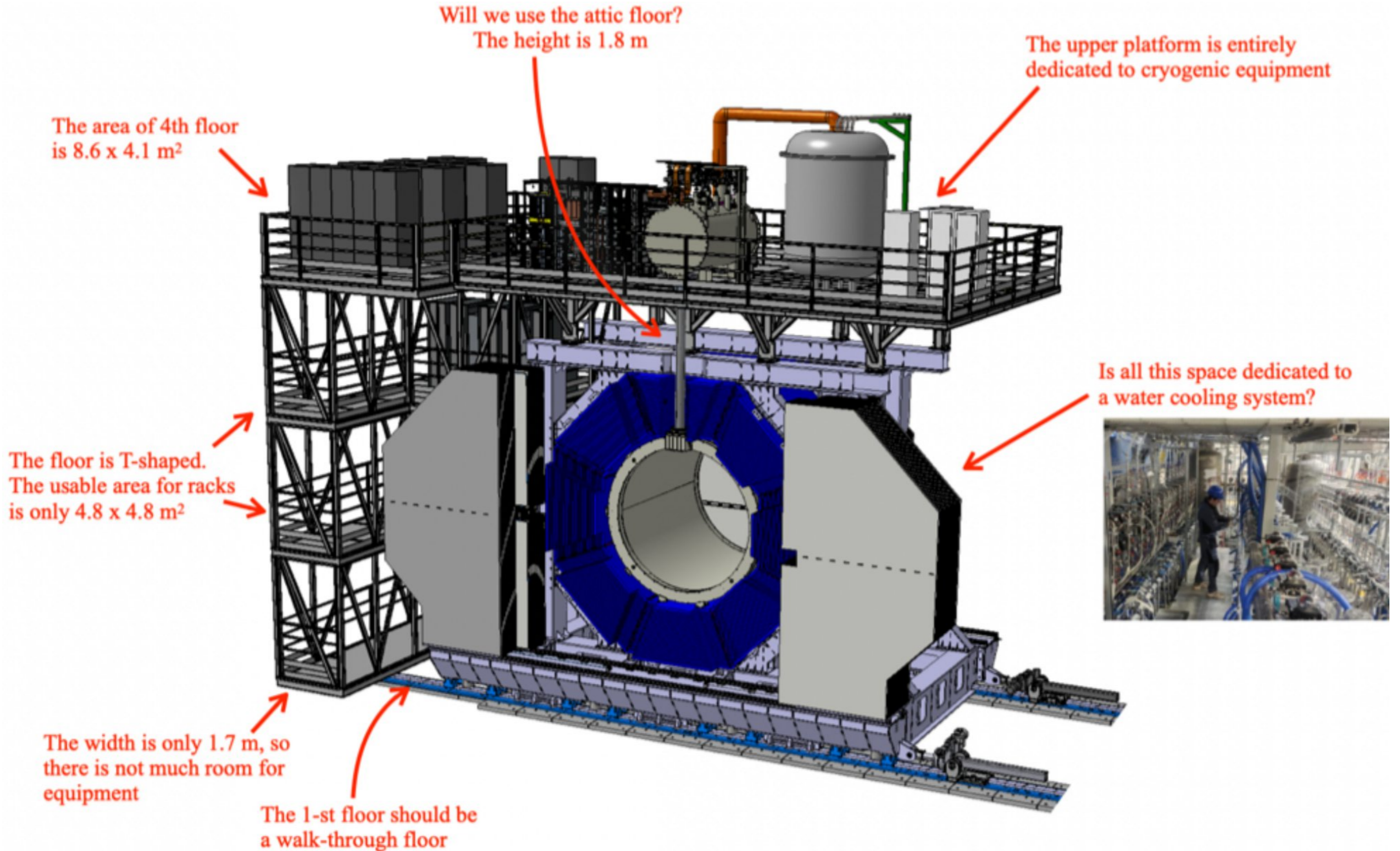

MISIS, Moscow

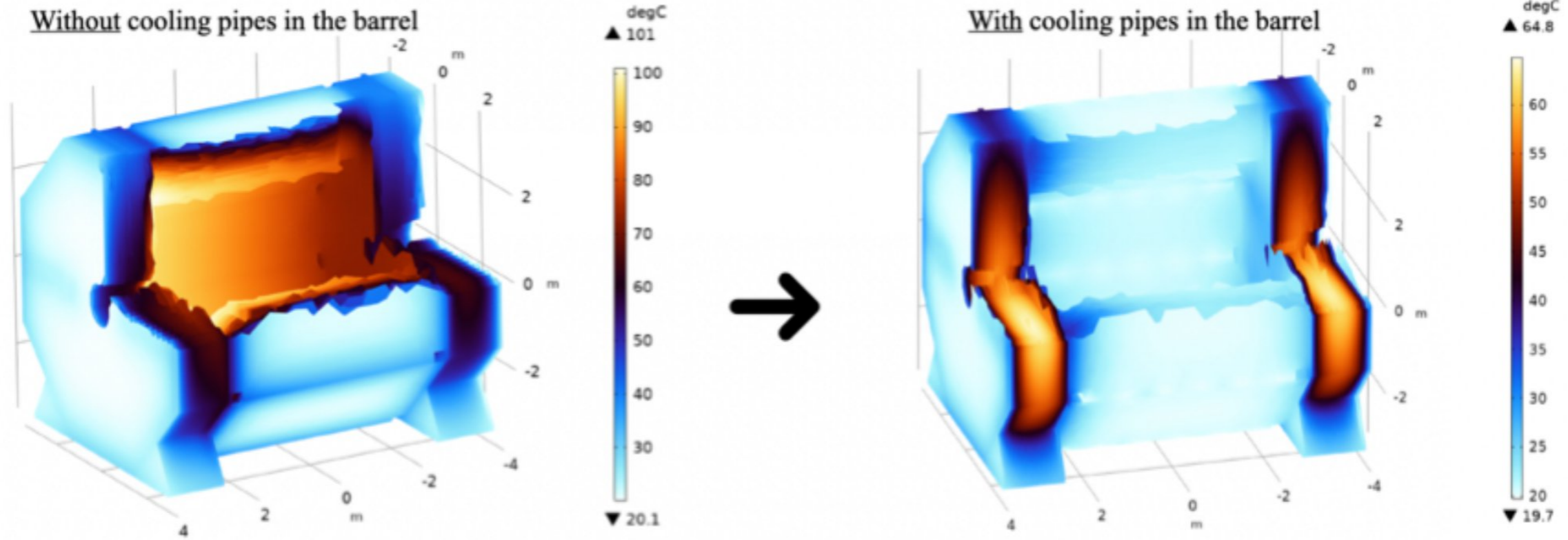

INP BSU, Minsk

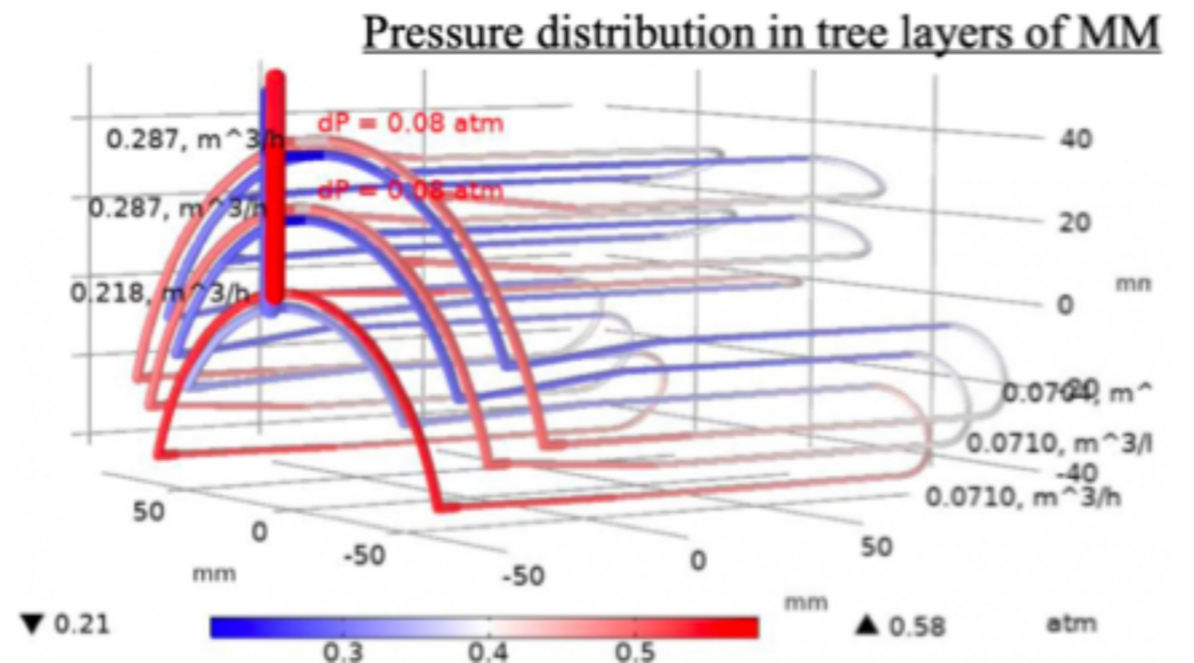
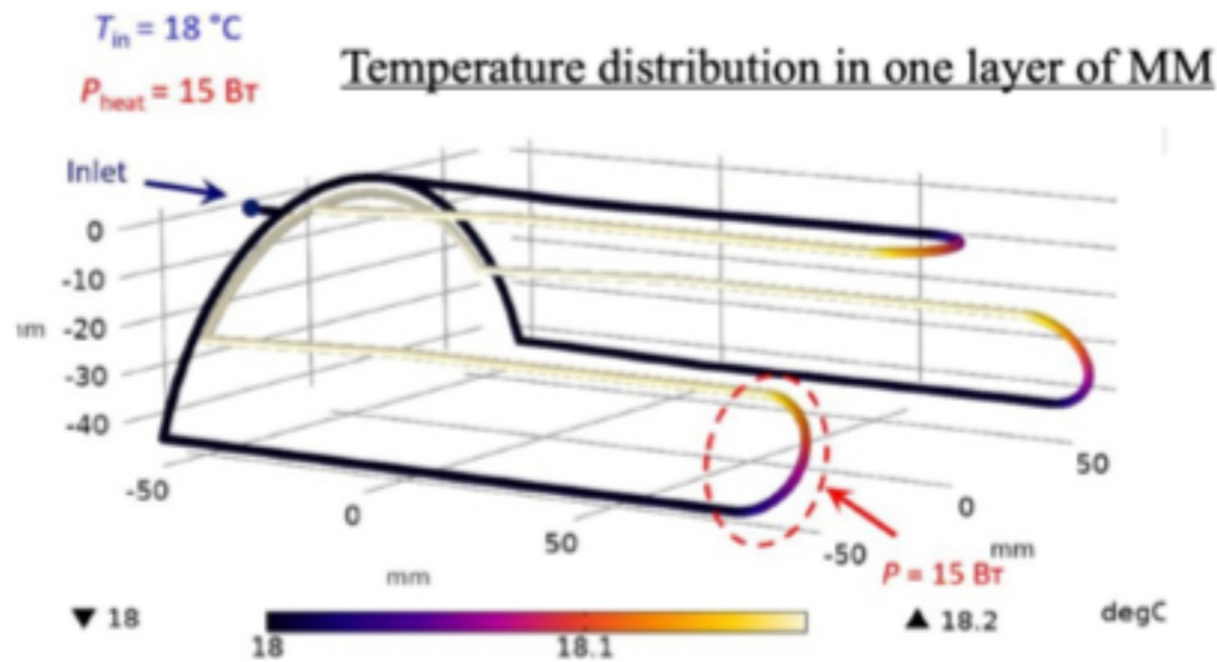

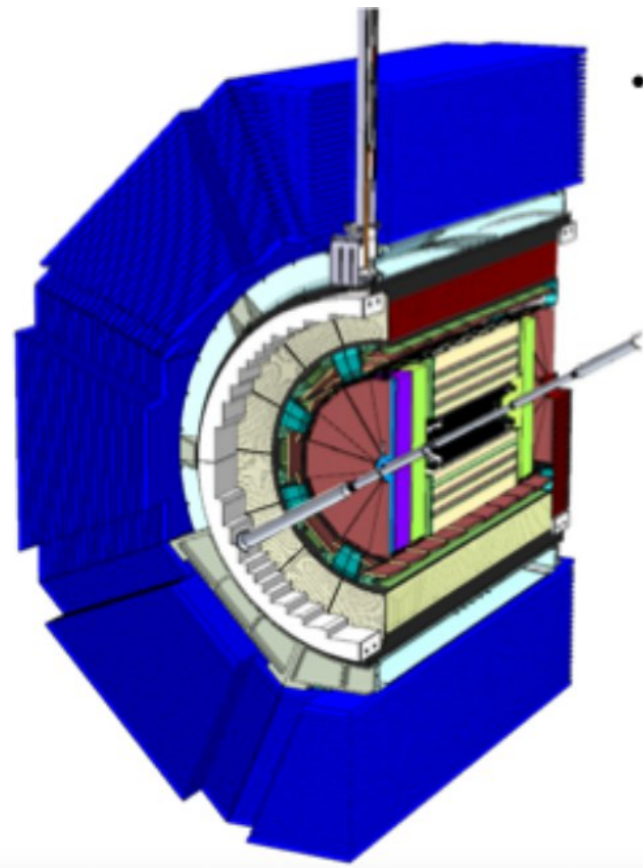

- Since the beginning of this year, the Design Bureau №2 of LHEP has been actively involved in the development of the detector's load-bearing structure. The work is coordinated with engineers from other groups

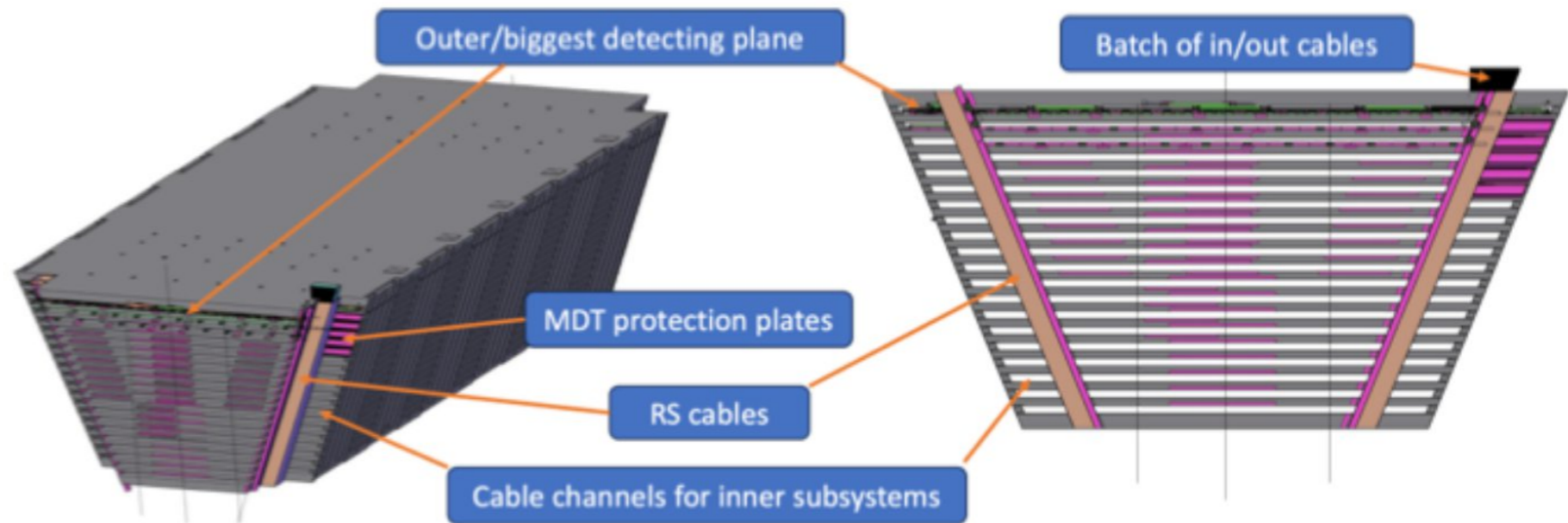

RS detector layer prototype

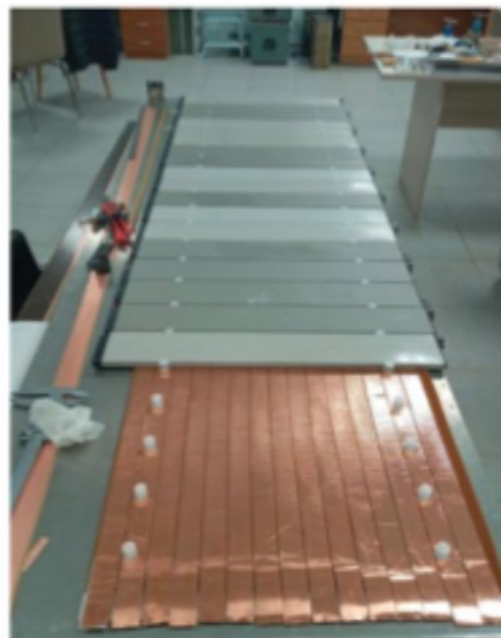
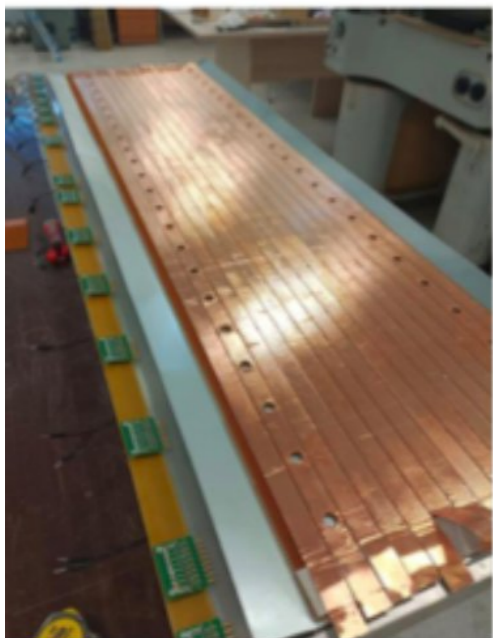

Injection molding machine for MDTs plastic details



Groups: JINR (Dubna), PNPI (Gatchina) and INP RK (Almaty)

R&D: thin straw tubes with ASIC solution

- ▶ **Straw R&D Test Stand for SPD/SHiP/Dune/DRD1 at SPS and PS (CERN) for definition of ASIC novel technology requirements**
- Test Runs with ASIC: VMM3, VMM3a, Tiger**
- 2021 (1 Run), 2022 (3 Runs), 2023 (3 Runs), 2024-2025 (5 Runs SPS, 3 Runs PS)
- most of results included to the SPD TDR
- R&D Test Run at NRC KI - PNPI, Gatchina in September 2025**
- ▶ **INP BSU, Minsk: new ASIC solution in progress**



SPD Interaction Point: Beam-Beam Counter (BBC)



The optical cables prototype test

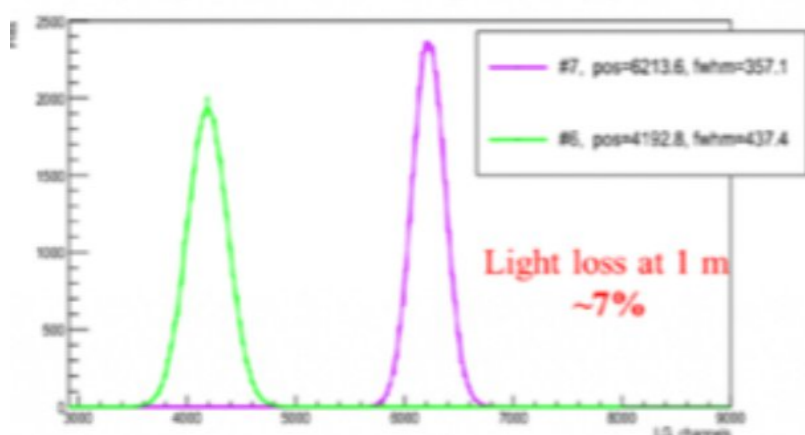

128 tiles (8x16)

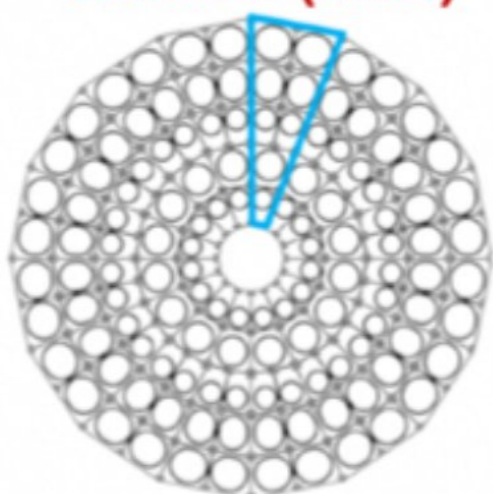

reduced prototype wheel (x2)
(at the 1-st stage)

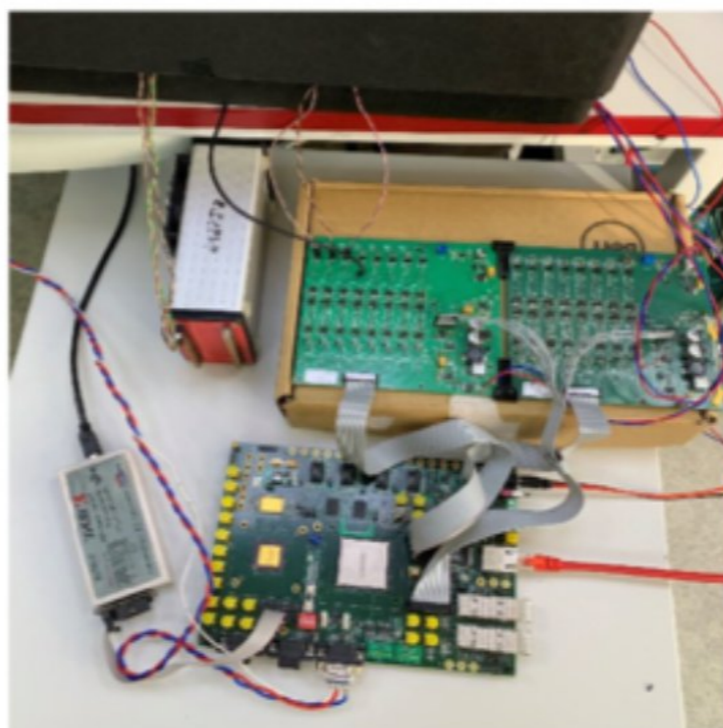

FEE & Readout system:

CAEN FERS-5200 (1)

for Phase 0

NEW ELECTRONICS (2)

for Phase ≥ 1

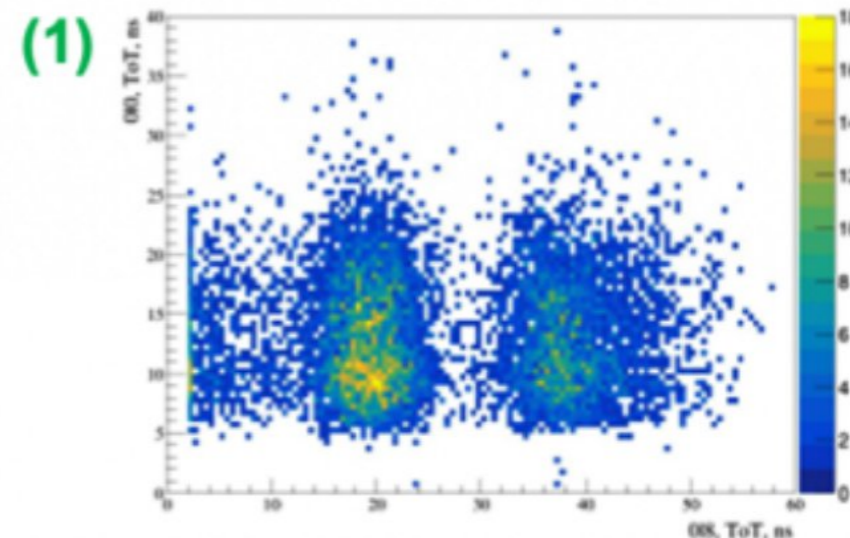

(2)

- Tests of the new electronics showed reasonable results
- The upgraded version of FEE with FPGA KINTEX-7 based readout system are under development
- The cables prototype with clear fiber produced by Kuraray has been developed and tested

Plans:

- I. The R&D phase for optical and transmission connectors, as well as methods of express sector checking to be continued.
- II. The manufacture of reduced BBC wheels (128 tiles each) for SPD Phase 0 is planned to the mid of 2025.

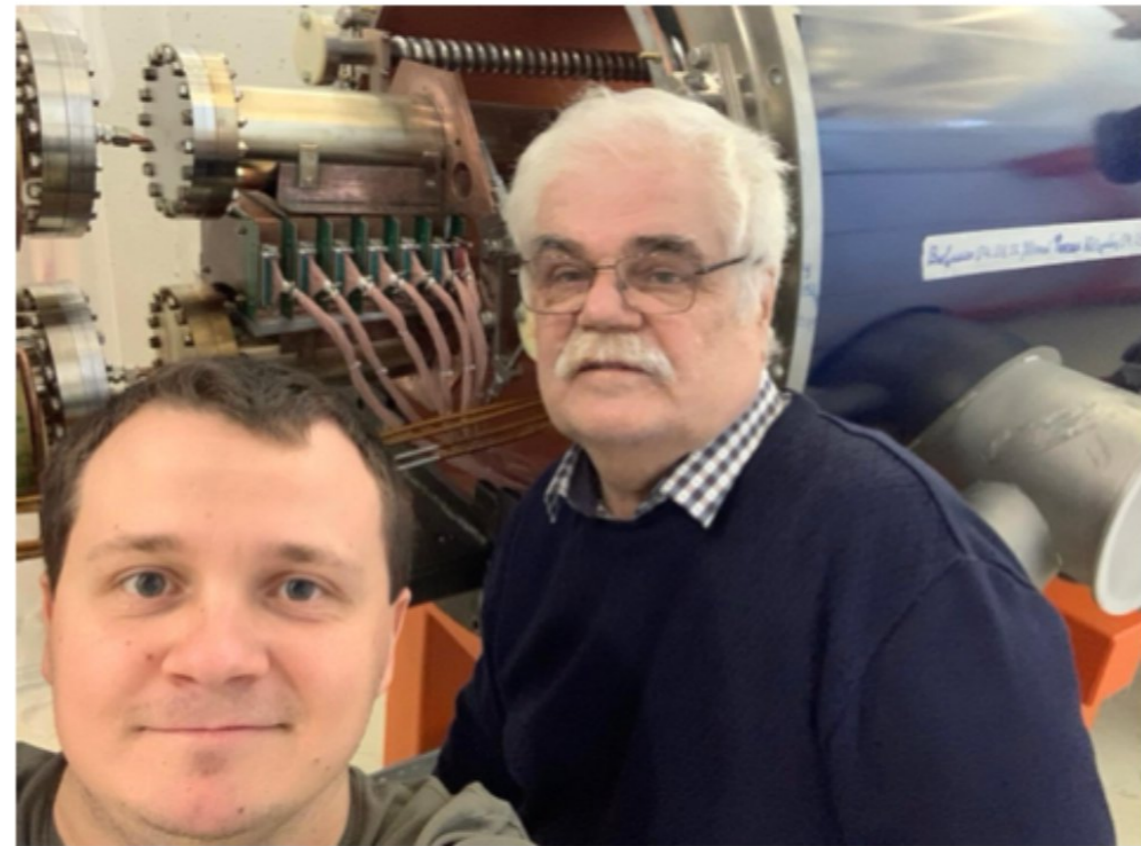
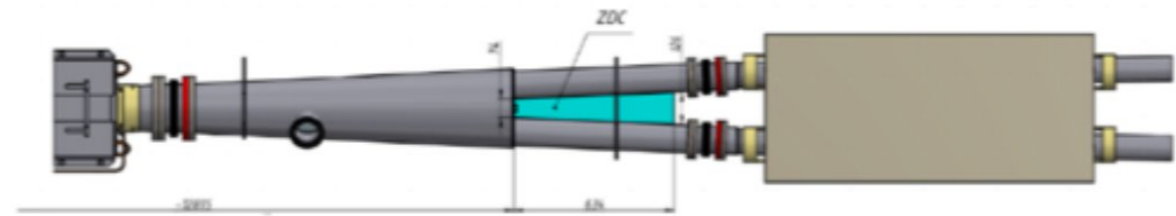
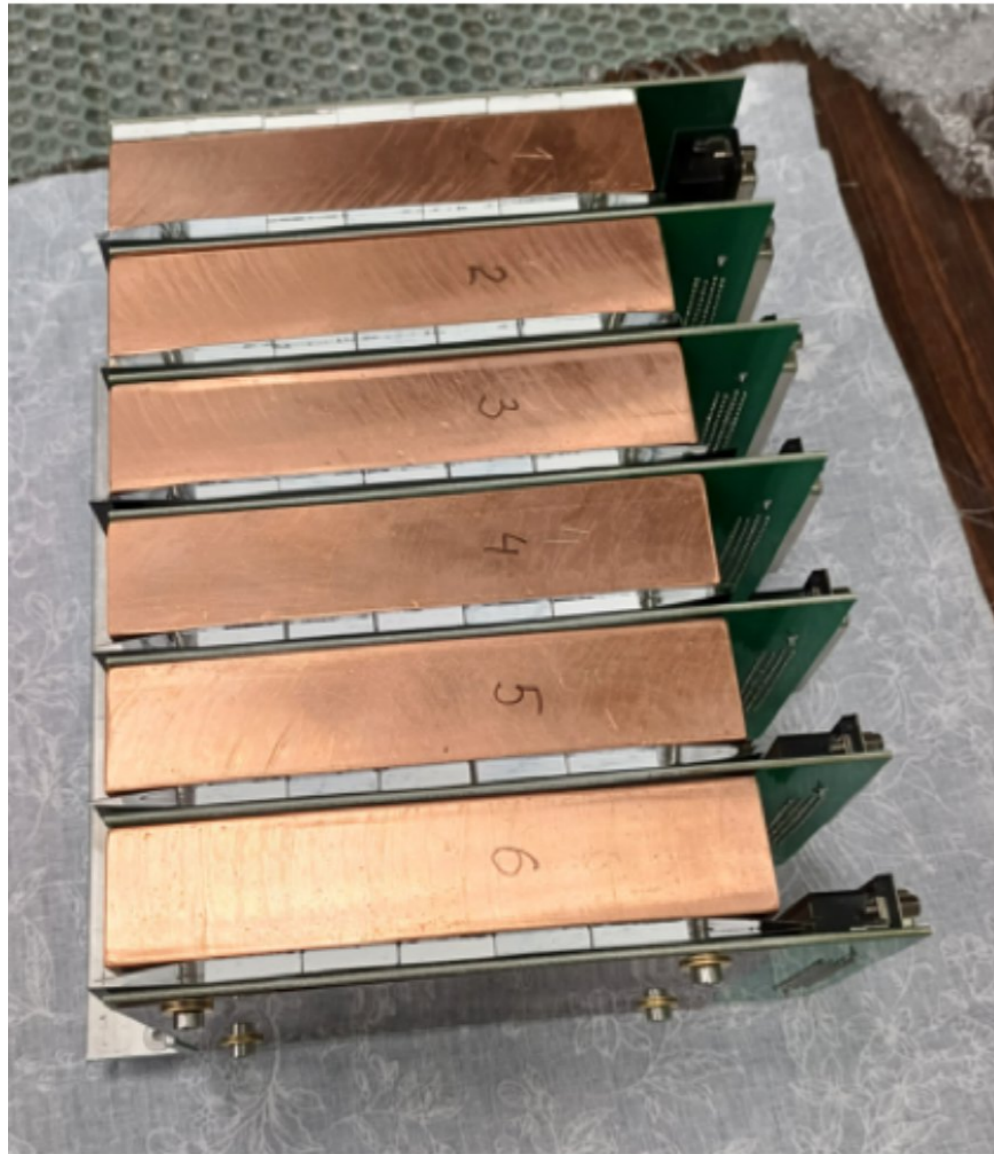

SPD Interaction Point:

- ▶ The 1st ZDC prototype is installed already
- ▶ The 2st ZDC prototype will be installed soon

- ▶ **Spin Physics Detector (SPD) – a universal detector at NICA Collider:**
Detail study of polarized and unpolarized (gluon) structure of proton and deuteron in pp- и dd- collisions at high luminosity up to $\sqrt{s} < 27$ GeV
- ▶ **Complementary probes: quarkonia (J/Psi and higher states), open charm and direct photons**
- ▶ **SPD should improve understanding of 3D-gluon structure:**
 - polarized gluon distributions
 - unpolarized PDF and TMD at large x in proton and deuteron
 - gluon transversity of deuteron ...
- ▶ **SPD physics program is complementary to studies at COMPASS++/AMBER, RHIC, AFTER@LHC, LHC-spin, EIC**
- ▶ **Wide physics program at the SPD 1-Stage:**
 - search for exotic resonances (glueball, penta- and tetra- quarks), ...
 - multiquarks fluctons and few-nucleon correlations ...
- ▶ **SPD TDR: <http://spd.jinr.ru> approved by JINR PAC in June 2024, published in the new JINR journal Natural Science Review (2024) v.1, p. 1**
- ▶ **SPD 1-Stage included into 7-year JINR plan 2024-2030**
- ▶ **SPD R&D: physics signal optimization, setup design optimization, production and testing of prototypes, preparation for production installation started at SPD IP**

SPD: dynamically developing and in a good shape!