

# Estimation of Inter Conductor Stray Capacitance for HVDC Transmission Line of Negative Neutral Beam Injector

Vishnudev M N<sup>1, a)</sup>, Deepak Parmar<sup>1, b)</sup>, Hardik Shishangiya<sup>1, c)</sup>, Agrajit Gahlaut<sup>2, d)</sup>,  
V Mahesh<sup>2, e)</sup>, M. Bandyopadhyay<sup>2, f)</sup> and Arun Chakraborty<sup>2, g)</sup>

<sup>a)</sup>Corresponding author: vishnudev.mn@iter-india.org

<sup>b)</sup> deepak.parmar@iter-india.org

<sup>c)</sup> hardik.shishangiya@iter-india.org

<sup>d)</sup> agrajit@ipr.res.in

<sup>e)</sup> vmahesh@ipr.res.in

<sup>f)</sup> mainak@ipr.res.in

<sup>g)</sup> arunkc@ipr.res.in

**Abstract.** Neutral beam injectors inject multi megawatt neutral beams, several tens of amperes and energies from few 100 kV to MV, into the tokamak for heating and diagnostic purposes. The neutral beams are produced through the route of neutralization of ion beams. The ion beams of machines like ITER shall use large area RF based negative ion sources, for plasma production, coupled to multi-grid (3-7), extractor and accelerator systems. Depending on the energy requirements and the beam optics the gaps between the extractor and accelerator stages can range between a few mm to few tens of mm. The multi-aperture multi-grid extractor accelerator systems also provide the route for the gas being fed in the ion source for the plasma production to escape to the surroundings. As a result, the gas density in the gaps is high and can lead to breakdowns often referred to as Paschen breakdowns. A major source of stored energy could be the inter conductor stray capacitance of the high voltage transmission line. These breakdowns could lead to damage of the grid segments and thereby considerable down time of the injector. One of the possible routes to reduce the stored energy could be to reduce the inter conductor stray capacitance by increasing the distance between the conductor and the outer ground cover. This will result in a transmission line with a complex geometry and direct estimation of inter conductor stray capacitance of such complex geometry is difficult. Hence a technique is proposed to estimate the inter conductor stray capacitance of a complex geometry transmission line.

A study has been carried out to estimate the inter conductor stray capacitance for various configurations of the transmission line using the method of stored energy in the COMSOL platform. The estimates for one such configuration have been validated experimentally from measured values of capacitance for a 1 m long prototype element. The results of these studies and the experimental observations shall be presented and discussed

## INTRODUCTION

In Neutral Beam Injectors (NBI), when neutral atoms injected to plasma [1], they travel in straight lines without being affected by magnetic field. The ion source produces the ions which are accelerated through a multi aperture system of either slots or circular holes carefully designed to minimize the aberrations of each beam-let. These grids are connected to high voltage power supplies (10kV to 1MV) to accelerate ions. The accelerated ion beam then passes through a gas cell neutralizer where the ions undergo charge exchange neutralization. Some of the ion beam passes through un-neutralized and some of the neutral beam is re-ionized in the neutralizer.

Ions in NBI are accelerated to desired energy by the application of high voltages to electrostatic multi-aperture grid plate systems in the ion source. Accelerated ions subsequently neutralized in a gas cell called "neutralizer". To maintain the electrostatic lens configuration, grid plates are closely packed and are parallel to each other. The distance between them are in range of millimeters. Paschen-breakdown (here it is called 'grid breakdown') between the grid plates occurs routinely during system conditioning phases due to the presence of high voltage (HV) and sufficient gas (@ sub-atmospheric pressure) [2]. When grid-breakdown occurs the stored energy of HV DC transmission system is dumped into the acceleration grids at the breakdown location and poses a danger to the grid surface by localized melting and spot formation.

Extraction and acceleration of negative ions to the required beam energy is carried out with help of high voltage regulated DC power supplies. High voltage transmission line connects the acceleration and extraction power supplies to copper grids in NBI system. A major contribution to the stored energy released during a grid breakdown comes from the inter-conductor stray capacitance in the high voltage transmission line [3,4]. The contribution of stored energy by HVDC transmission line ranges from 60% to 85%. The stored energy in inter conductor stray capacitance may limit the performance of NBI systems as they become larger and operate at higher voltage. The inductance of the HVDC transmission line limits the peak current but it will give rise to voltage spike during grid breakdown. During grid breakdown the stored energy of transmission line is dumped into grids which could lead to damage of grids. In order to reduce the conductor stray capacitance of HV transmission line a proper estimation of the inter-conductor stray capacitance is required. This paper discusses a methodology to estimate the inter-conductor stray capacitance of such a high voltage transmission line. Estimation of inter-conductor stray capacitance of is done for a typical model of HVDC transmission line configuration in COMSOL [5] and it is validated by measurement of the capacitance of a 1 m prototype of HVDC transmission line.

## DEVELOPMENT OF TYPICAL MODEL OF HVDC TRANSMISSION LINE

The methodology for estimation of inter-conductor stray capacitance using a simulation is validated by capacitance measurement of a 1 m long prototype of HV DC transmission line. Hence typical model of transmission line is developed to establish the methodology for estimation of inter conductor stray capacitance. High voltage DC transmission line connects Acceleration Power Supply System (APSS, -35kV 15A) and Extraction Power Supply System (EPSS, -11kV 35A) [6] with Twin Source [7].

The implementation of vertical topology requires insulator support blocks to be provided at regular intervals to maintain the inter conductor distance constant as per Fig. 1 (a) and (b). Insulator support block are made of polyethylene with a dielectric constant 2.35. The placement of insulator supports at regular (at 1 m) intervals.

The HV line would be supported by insulator block with dimensions as per Fig. 1(b) at regular interval of 1 m to maintain the inter conductor distance constant and aluminium ground cover would be provided surrounding all the three HV lines (as seen in Fig 1 (c)). The implementation of high voltage transmission line in COMSOL platform is as per Fig. 2.

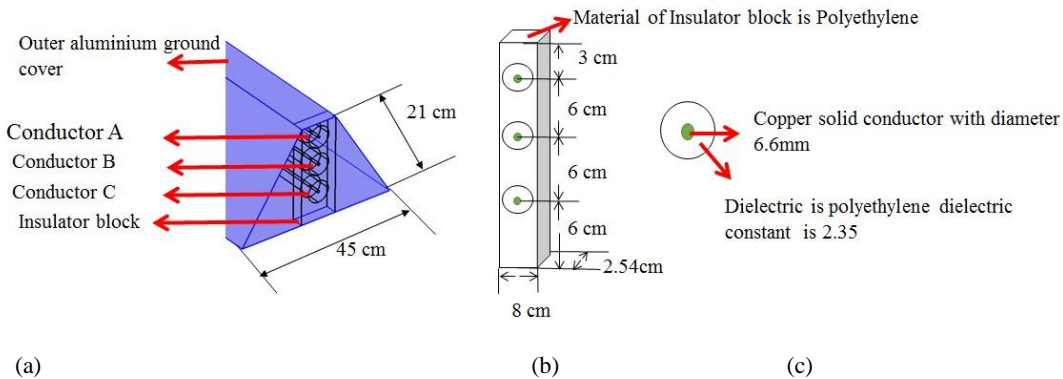

Figure 1 Typical model of HVDC transmission line with insulator block dimensions.

## ESTIMATION OF INTER CONDUCTOR STRAY CAPACITANCE IN COMSOL PLATFORM

The COMSOL platform is used to estimate the inter conductor stray capacitance of above mentioned configurations [8]. In COMSOL lumped parameters such as capacitance is calculated by energy method [9]. Equation 1 forms basis of calculation of capacitance C from integral of electric energy density ( $W_e'$ ) where  $\int_{\Omega}$  is the volume integral over the entire geometry and V is the electric potential.

$$C = \frac{2 \int_{\Omega} W_e' d\Omega}{V^2} \quad (1)$$

The estimation of inter conductor stray capacitance parameter involve the earlier mentioned methodology of obtaining the electrostatic energy of the system with known electric potential applied to a conductor with rest of the system being grounded. Thus for three conductor system

$$\begin{bmatrix} 1 & 1 & 0 \\ 1 & 0 & 1 \\ 0 & 1 & 1 \end{bmatrix} \begin{bmatrix} C'_{AC} \\ C'_{AB} \\ C'_{BC} \end{bmatrix} = \begin{bmatrix} \frac{2W_e(A^+)}{U^2} \\ \frac{2W_e(C^+)}{U^2} \\ \frac{2W_e(B^+)}{U^2} \end{bmatrix} \quad (2)$$

$$\begin{bmatrix} C'_{AC} \\ C'_{AB} \\ C'_{BC} \end{bmatrix} = \frac{2}{U^2} \begin{bmatrix} W_e(A^+) \\ W_e(C^+) \\ W_e(B^+) \end{bmatrix} \begin{bmatrix} 1 & 1 & 0 \\ 1 & 0 & 1 \\ 0 & 1 & 1 \end{bmatrix}^{-1} \quad (3)$$

Where  $W_e(A^+)$  is Electrostatic energy of the system when Conductor A is applied with potential and U is the applied potential as per Fig. 3. Inter conductor stray capacitance could be estimated from known electrostatic energy and electric potential as per Eq. 3. It is summarized as Table 1.

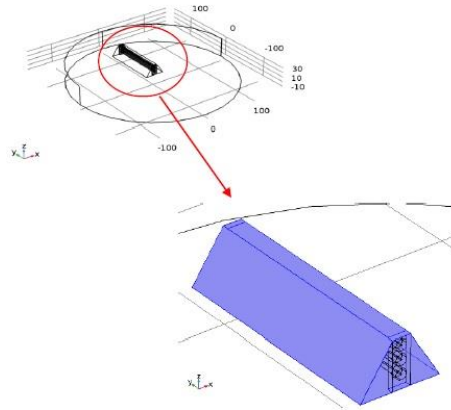

Figure 2 Implementation of High voltage transmission line in COMSOL platform.

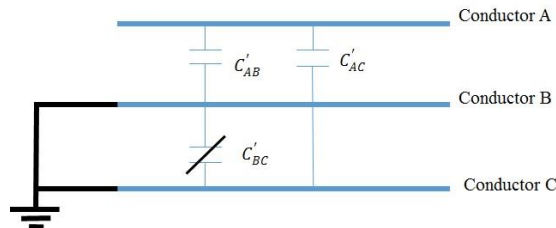

Figure 3 Three Conductors with potential being applied to conductor A and rest of the conductors grounded

**TABLE 1** Estimated inter conductor stray capacitance for vertical topology of HVDC transmission line

Capacitance	Estimated value(pF)
$C'_{AB}$	18.45
$C'_{AC}$	17.22
$C'_{BC}$	15.03

## MEASUREMENT OF CAPACITANCE FOR VERTICAL TOPOLOGY PROTOTYPE

The effective inter conductor stray capacitance between three conductors is estimated from the equivalent capacitance with electric potential(=1V) being applied to one conductor and other being grounded [10,11]. Consider 3 conductors A, B, C Fig. 4. The effective inter conductor stray capacitance between conductor A and B is  $C'_{AB}$ . Similarly, effective inter conductor stray capacitance  $C'_{AC}$  and  $C'_{BC}$  exist between other two conductors. When conductor B and C are grounded, the effective equivalent capacitance  $C_{eqvt}(A^+)$  is  $C'_{AB} + C'_{AC}$ . Thus

$$\begin{bmatrix} 1 & 1 & 0 \\ 1 & 0 & 1 \\ 0 & 1 & 1 \end{bmatrix} \begin{bmatrix} C'_{AC} \\ C'_{AB} \\ C'_{BC} \end{bmatrix} = \begin{bmatrix} C_{eqvt}(A^+) \\ C_{eqvt}(C^+) \\ C_{eqvt}(B^+) \end{bmatrix} \quad (4)$$

$$\begin{bmatrix} C'_{AC} \\ C'_{AB} \\ C'_{BC} \end{bmatrix} = \begin{bmatrix} C_{eqvt}(A^+) \\ C_{eqvt}(C^+) \\ C_{eqvt}(B^+) \end{bmatrix} \begin{bmatrix} 1 & 1 & 0 \\ 1 & 0 & 1 \\ 0 & 1 & 1 \end{bmatrix}^{-1} \quad (5)$$

1meter prototype HVDC transmission line is fabricated as per Fig. 5(a). Inter conductor stray capacitance is estimated by measurement of effective equivalent capacitance by HIOKI impedance analyser IM3570 as per Fig. 5(b). The effective equivalent capacitance  $C_{eqvt}(A^+)$  is measured with conductor B and C shorted with outer ground cover conductor by impedance analyzer. Similarly,  $C_{eqvt}(C^+)$  and  $C_{eqvt}(B^+)$  are measured. Inter conductor stray capacitance  $C'_{AB}$ ,  $C'_{AC}$  and  $C'_{BC}$  are estimated from measured effective equivalent capacitance via Eq. 5.

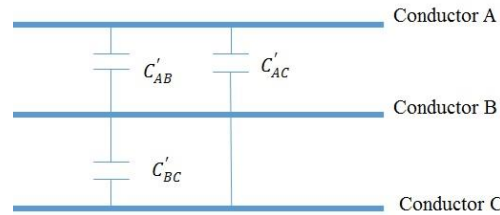

Figure 4 Inter conductor stray capacitance for 3 conductors

**TABLE 2** Comparison of simulated and measured values Inter conductor stray capacitance for vertical topology of HVDC transmission line

Capacitance	Simulated value(pF)	Measured value(pF)
$C'_{AB}$	18.45	18.42
$C'_{AC}$	17.22	17.17
$C'_{BC}$	15.03	15.41

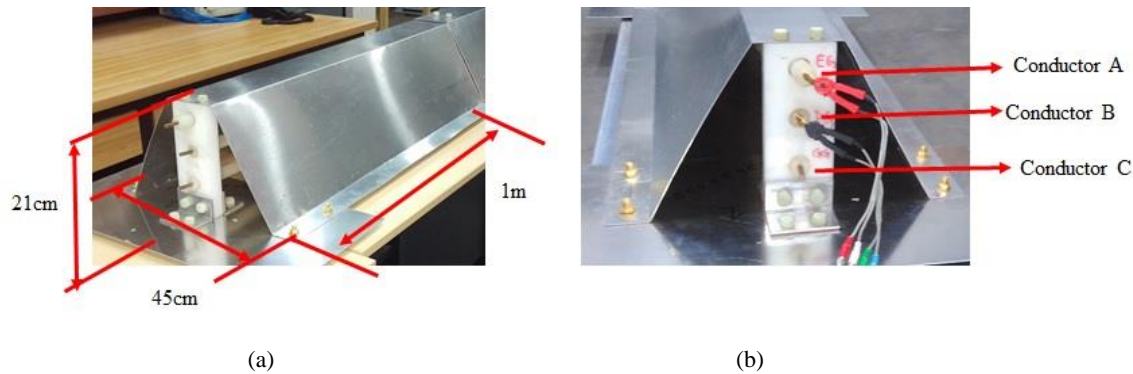

Figure 5 Prototype of vertical topology of HVDC transmission line.

## RESULTS AND DISCUSSIONS

Inter conductor stray capacitance of different topologies are estimated analytically from electrostatic simulation and verified with measurement of capacitance of 1m long prototype. For vertical topology, inter conductor capacitance is estimated for 1mtr long prototype and summarized as Table 2.

Figure 6 and Fig. 7 represent the electric contour and electric potential contour with Acceleration power supply system (APSS, -35kV 15A) and Extraction power supply system (EPSS, -11kV 35A) of Twin source. As seen in electric field contours of transmission line of linear topology Fig. 6, the electric field with maximum density end at top and bottom ground plate because of shorter distance between conductor and ground plane. The distance between conductor and side walls are quite large in comparison with top and bottom ground planes. Thus for analytical estimation of inter conductor stray capacitance only top and bottom ground planes are considered for inter conductor stray capacitance estimation.

The difference in simulation and measured values could be due to the spacing of the conductor may not be uniform throughout the length of prototype, though insulator post/spacers are provided at one-meter length. There is a fair agreement between measured and simulated values [12]. The difference in measured and simulated values range from 0.15% to 3% [13,14].

## SUMMARY AND NEXT STEPS

The methodology for estimation of the inter conductor stray capacitance of different configuration of transmission line is discussed. The exercise helped to estimate inter conductor stray capacitance of vertical topology of High Voltage DC transmission line configuration. Estimation of inter conductor stray capacitance in COMSOL platform was carried out and the corresponding obtained result of vertical topology is further confirmed from capacitance measurement of 1m long prototype linear topology transmission line in similar configuration.

Analytical estimation of high voltage dc transmission line vertical configuration could be carried out to infer if the values of inter conductor stray capacitance estimated matches with simulation and measured results. The variation of the same with length of transmission line could be done to infer the values of stray capacitance at greater length. The experimental validation by energy measurement of 1mtr long prototype could be done to compute the store energy and thus could be validated with stored energy estimated from computed capacitance value of aforesaid methodology. Also, transmission line modelling with computed parameter value could be done to obtain voltage, current waveforms and stored energy of transmission line in MATLAB platform.

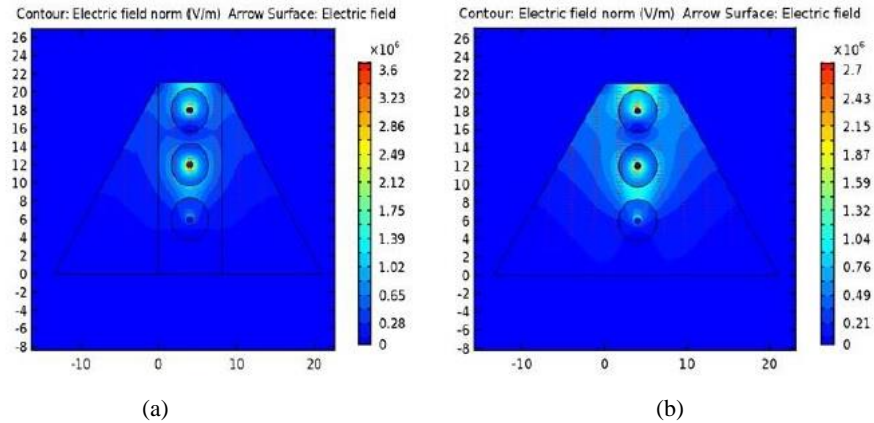

Figure 6 Electric field contour of High Voltage DC transmission line

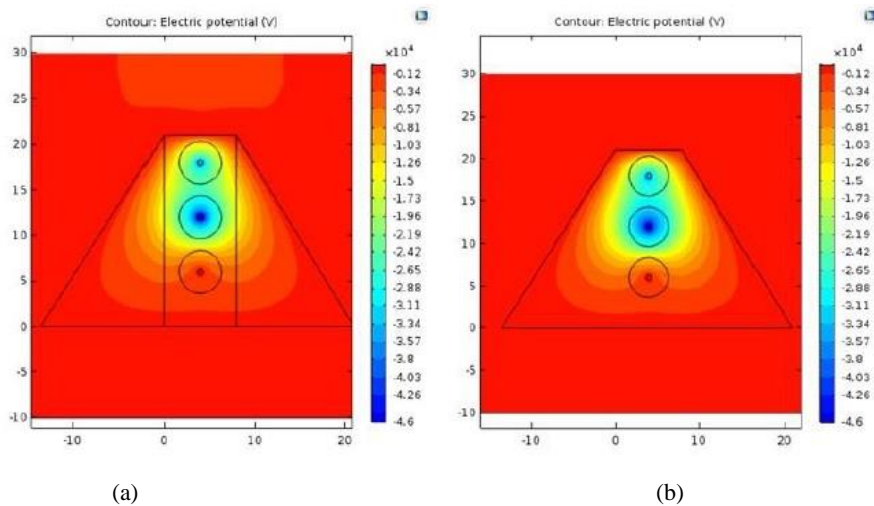

Figure 7 Electric potential contour for High Voltage DC transmission line

## REFERENCES

1. J A Wesson, in Tokamaks Third Edition, edited by J Wesson (Oxford university press, 2004), p. 249.
2. Bandyopadhyay M., "Two rf driver based negative ion source experiment", IEEE Transactions on Plasma Science 42, 624 (March 2014).
3. (Julich 1982), H.M. Owren, U.R. Baker, K.H. Berkner, D.B. Hopkins & D.J. Massoletti, "The effect of capacitive stored energy on neutral beam accelerator performance", 12th Symposium On Fusion Technology.
4. Bigi, M., "Protections against grid breakdowns in the iter neutral beam injector power supplies", Fusion Engineering and Design (2007).
5. Riba, Jordi-Roger., "Analysis of capacitance to ground formulas for different high-voltage electrodes", Energies 11, 1090 (2018).
6. Gahlaut, A. "Power supply system for negative ion source at ipr", Journal of Physics: conference series 208, 012030 (2010).
7. (Austin, Texas USA, May 2015), Deepak Parmar, H. Shishangiya, Vishnudev, M. Bandyopadhyay, R. Yadav, J. Bhagora, S. Shah, Dass Sudhir, H. Tyagi, A. Chakraborty, V. Mahesh, A. Gahlaut, K.G. Parmar, B. Prajapati, J. Soni, R. Pandey, G. Bansal, K. Pandya "Design and development of electrical system for twin source," 26th IEEE Symposium on Fusion Engineering.

8. (Hannover 2008), H. Lorenzen, J. Timmerberg, S. Mylvaganam “Calculation of cable parameter for different cable shapes”, Excerpt from Proceedings of COMSOL Conference.
9. Comsol 5.2, ac dc user guide.
10. J. D. Ling and A. E. Ruehli, in, Interconnection Modelling Third edition, (Elsevier Publishers B V, North Holland, 1987) p. 211.
11. C. R. Paul, Analysis of Multi Conductor transmission line, Second Edition (John Willey and sons, 2008) p. 160.
12. Raj, R Gokul., “Relative permittivity of dielectrics from scaling relation of capacitance,” Measurement 151, 107174 (2020).
13. Peres, J., “Accurate numerical method to evaluate the capacitances of multi-conductor power cables”, Electric Power Systems Research,103, 184– 191 (2013).
14. Liu, X., “Analytical estimation method of winding parasitic capacitance for high-frequency high-voltage application”, IEEE Access Volume 8 (2020).