



# Combined LXe/Crystal calorimeter for low energy $e^+e^-$ experiments

*Kirill Mikhailov*

*on behalf of the CMD-3 collaboration*

# The VEPP-2000 collider at Novosibirsk Budker INP

- Ultimate luminosity at 2 GeV:  $4 \times 10^{31} \text{ cm}^{-2} \cdot \text{s}^{-1}$   
Operated c.m.s. energy : 0.3 – 2 GeV
- Two detectors:  
    CMD3 (Cryogenic Magnetic Detector)  
    SND (Spherical Neutral Detector)
- Collected luminosity (08.03.21):  $2 \times 300 \text{ pb}^{-1}$

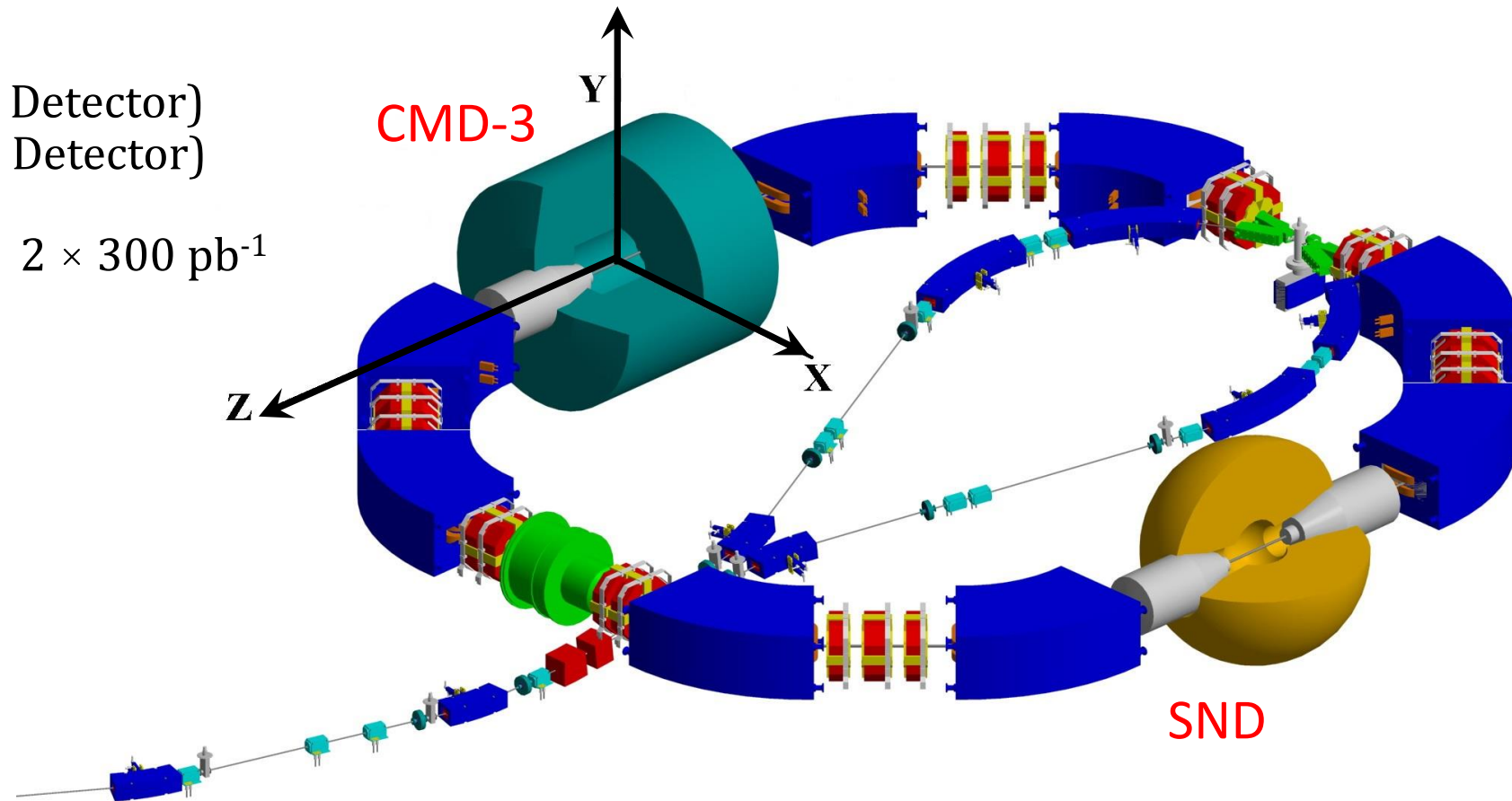

# CMD-3 detector, combined barrel calorimeter

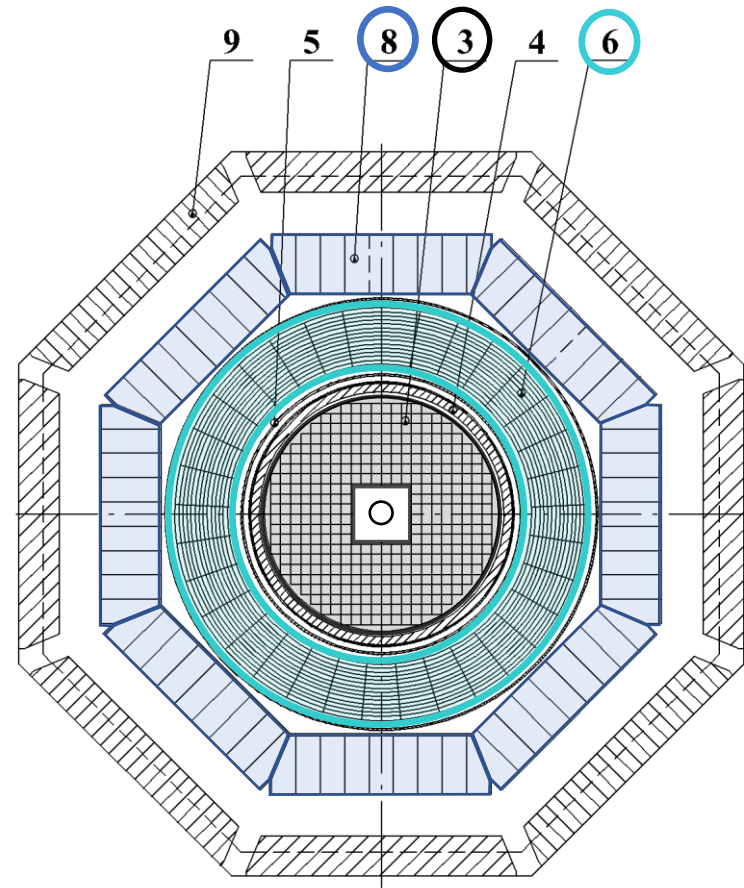
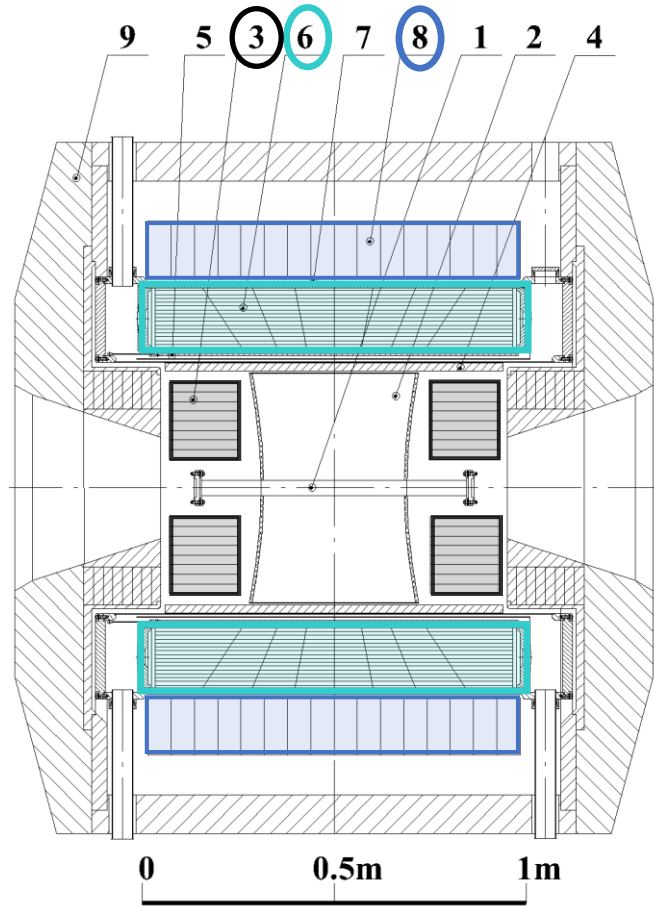

The main idea of combined LXe-CsI calorimeter is to get the system with good energy and spatial resolution for reasonable price.

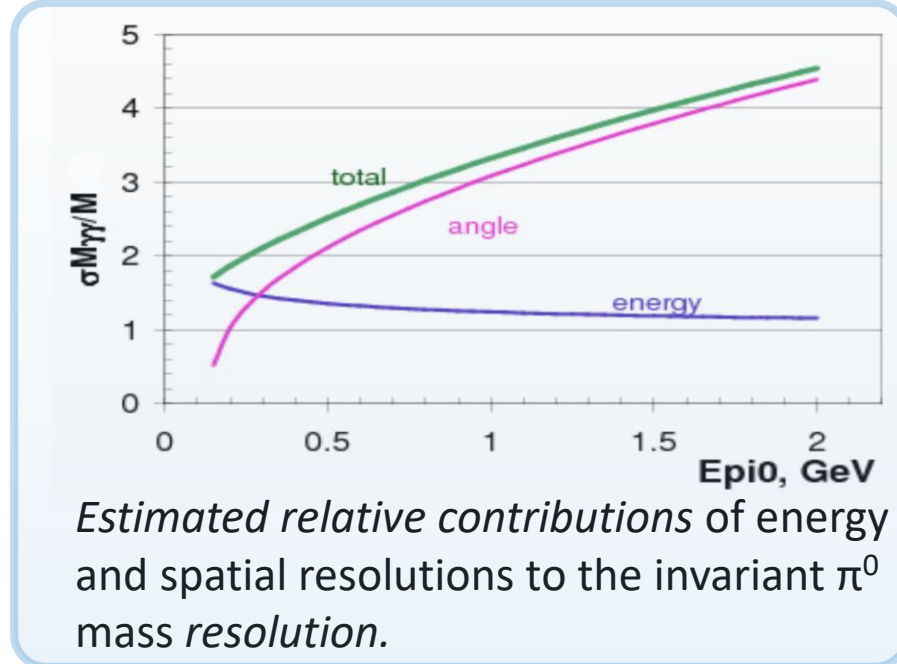

- Calorimetry subsystems :** Barrel : 6 – Liquid Xenon (LXe) , 8 – Cesium Iodide crystals (CsI)  
 Endcap: 3 – Bismuth Germanium Oxide crystals (BGO)
- Tracking subsystems:** 5 – SC solenoid ( $0.13X_0$  , 13 kGs), 2 – Drift chamber, 4 – Z-chamber

# CsI sensitive volume structure

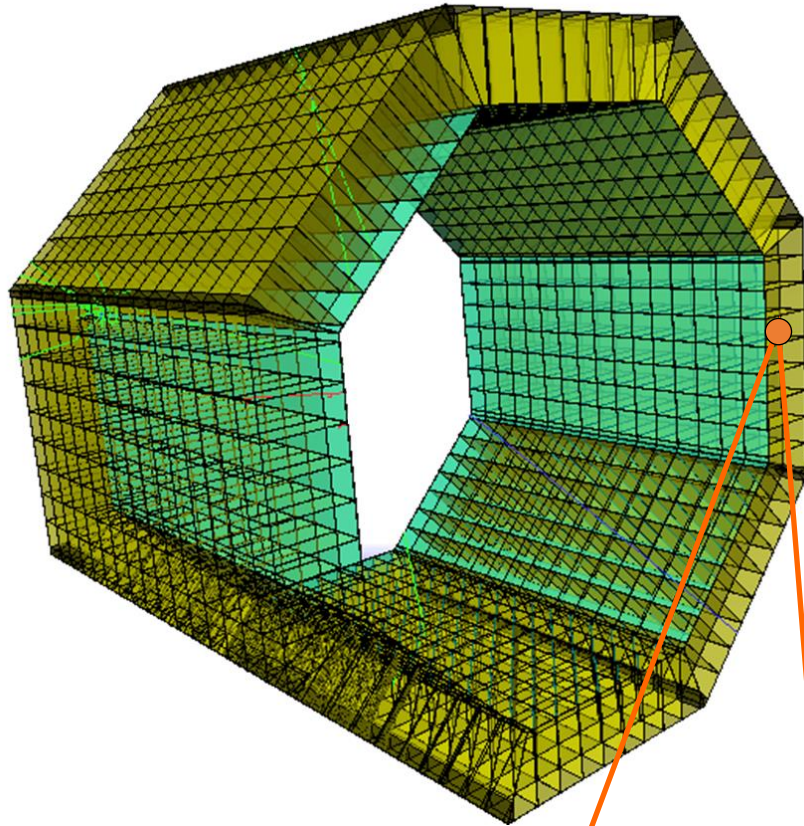

## Main CsI calorimeter parameters:

- **Single crystal:** CsI(Tl) or CsI(Na) **6 x 6 x 15 cm<sup>3</sup>** size
- Light output nonuniformity: < 10 %
- Crystal readout: **Hamamatsu S2744-8 PIN photodiode.**
- Structure: 8 octants × 9 (“lines”) × 16 counters
- **Num. of electronics chan.:** **1152 (counters)**
- Total mass: 2.8 tons
- **Thickness:** 15 cm : **8.1X<sub>0</sub>**

Crystals parameters: →

Characteristic	CsI(Tl)	CsI(Na)
Density, g/cm <sup>3</sup>	4.51	
Radiation length X <sub>0</sub> , cm	1.86	
Nuc. Interaction length, cm	39.3	
Moliere radius, cm	3.57	
(dE/dX) <sub>min</sub> , MeV/cm	5.6	
Wavelength of max. emission, nm	560	420
Decay time	1000	600
Light yield, phot./MeV	45000	30000
Hygroscopicity	weak	

## Single crystal (counter)

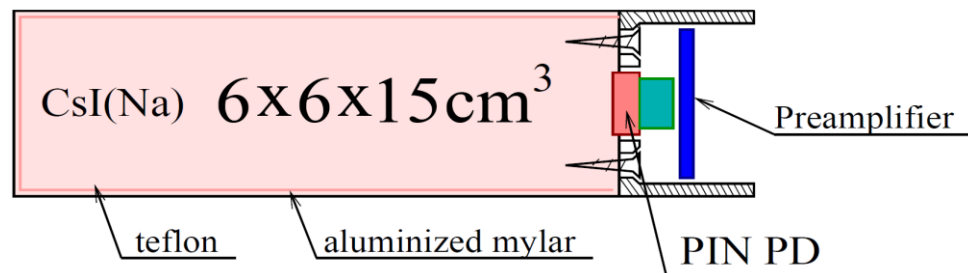

# *The Csl calorimeter parts:*

The single octant of Csl calorimeter



Charge sensitive preamplifier and  
**PIN PD Hamamatsu S2744-8**

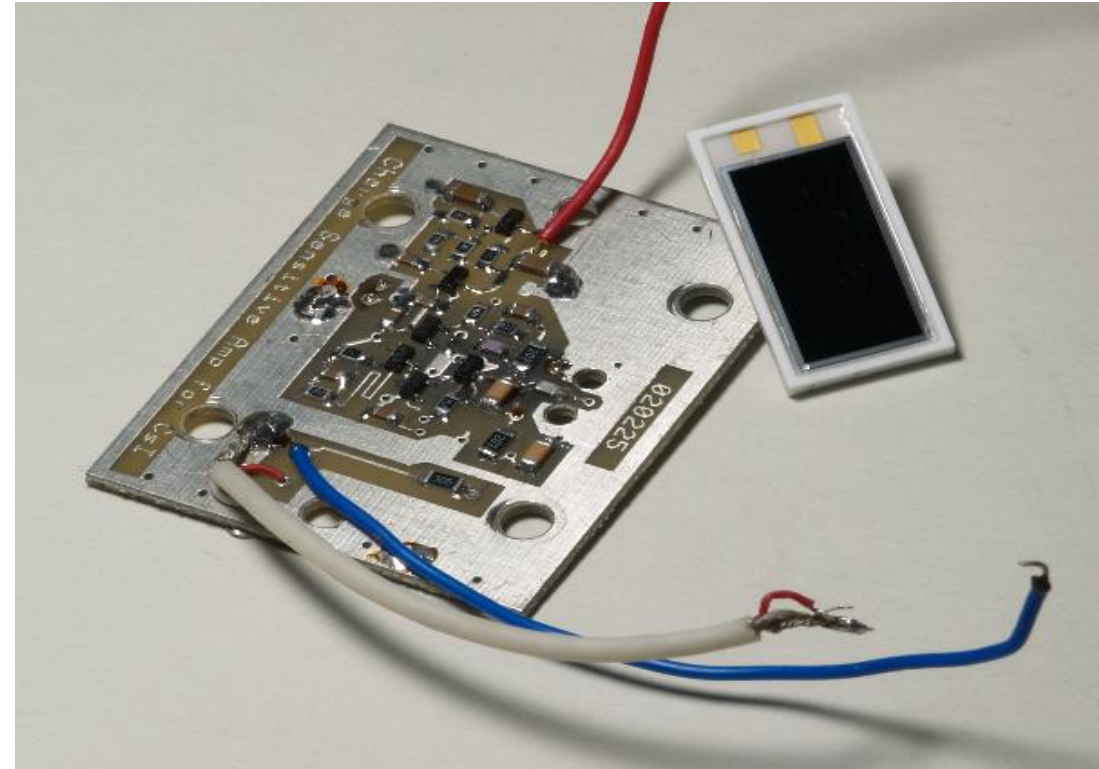

# LXe sensitive volume structure

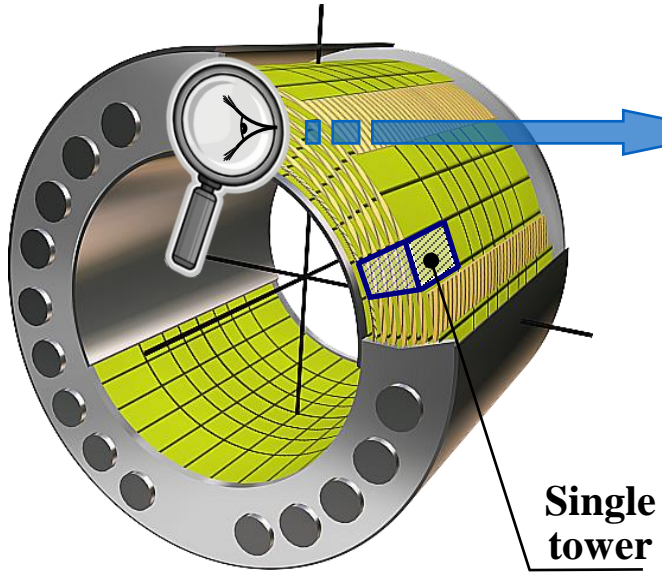

LXe volume segmentation

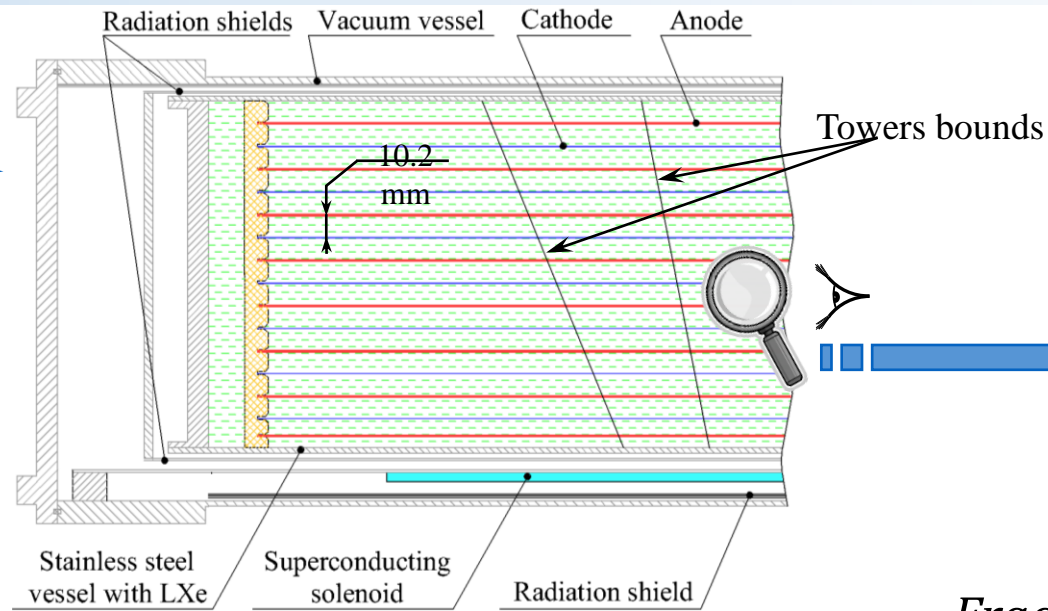

Electrodes at ZY plane

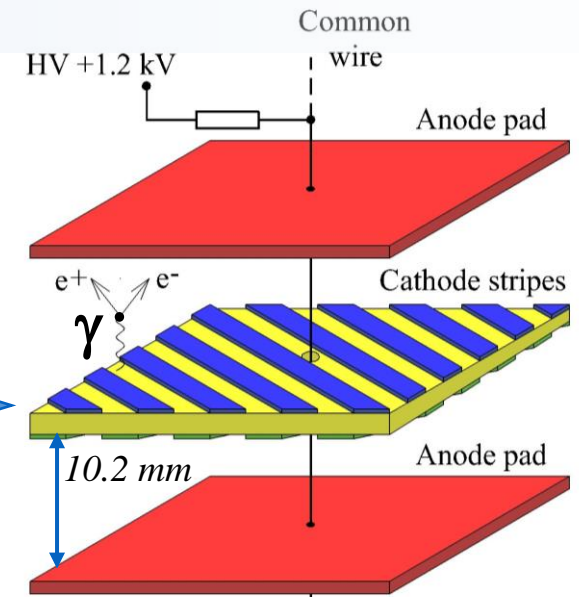

Fragment of two Ionization gaps  
( Cathode strips on both sides Provide semitransparent structure ! )

The calorimeter consists of a set of ionization chambers with 7 cylindrical **cathodes** and 8 **anodes** divided by a 10.2 mm gaps. The electrodes are made of 0.5–0.8 mm G-10 foiled with copper and fixed and the ends of cylindrical vessel, filled with liquid Xenon. The vessel is made of stainless still with inner and outer cylinders wall width 3.7 mm and 3 mm, respectively.

The conductive surfaces of the **anode cylinders** are divided into rectangular pads and joined with common signal wire thereby forming “**towers**”, oriented to the interaction point. So, the tower is a minimum sensitive volume for energy measurement.

The conductive surfaces of the **cathode cylinders** are divided into splitted **strips**. The strips on the opposite sides of the cylinder are mutually perpendicular. Such structure provides **coordinate and  $dE/dX$**  measurement.

# The LXe calorimeter parameters:

- LXe sensitive volume segmentation:

**Towers** –  $8Z \times 33(R-\phi) = 264$  chan.  
size  $\sim 10 \times 10 \times 15$  cm<sup>3</sup> (Molière)  
(energy measurement)

**Strips** –  $16$  gaps  $\times$  ( $\sim 132$  strips/gap) = **2112** chan  
(hit coordinates and  $dE/dx$  measurement)

- The value of electric field in the gap:  $E \sim 1$  kV/cm
- Max. drift time of electrons in the gap:  $4.5 \mu\text{s}$
- The concentrate of electronegative impurities:  $\sim 10^{-8}$ .
- Attenuation length of electrons:  $\sim 15$  -20 mm.
- LXe volume: 400 liters (1200 kg)
- Thickness:**  $\sim 15$  cm : **5.4 X0**

Liquid Xenon main parameters in comparison with some other noble gases:

<i>Parameters</i>	<i>LXe</i>	<i>LKr</i>	<i>LAr</i>
<i>Z</i>	<b>54</b>	36	18
<i>A</i>	<b>131</b>	84	40
<i>Density, g/cm<sup>3</sup></i>	<b>2.95</b>	2.42	1.4
<i>Radiation length X<sub>0</sub>, cm</i>	<b>2.87</b> 😊	4.7	14.0
<i>Nuc. Interaction length, cm</i>	<b>58</b>	62	85
<i>Moliere radius, cm</i>	<b>5.2</b>	5.9	9.0
<i>(dE/dX)<sub>min</sub>, MeV/cm</i>	<b>3.71</b>	3.28	2.11
<i>W, eV/pare</i>	<b>15.6</b>	20.5	23.4
<i>Boiling/melting point, K (1 bar)</i>	<b>165/161</b>	120/116	87/84
<i>~ Price, \$/liter STP )</i>	<b>15</b> 😞	0.5	-

# LXe calorimeter parts

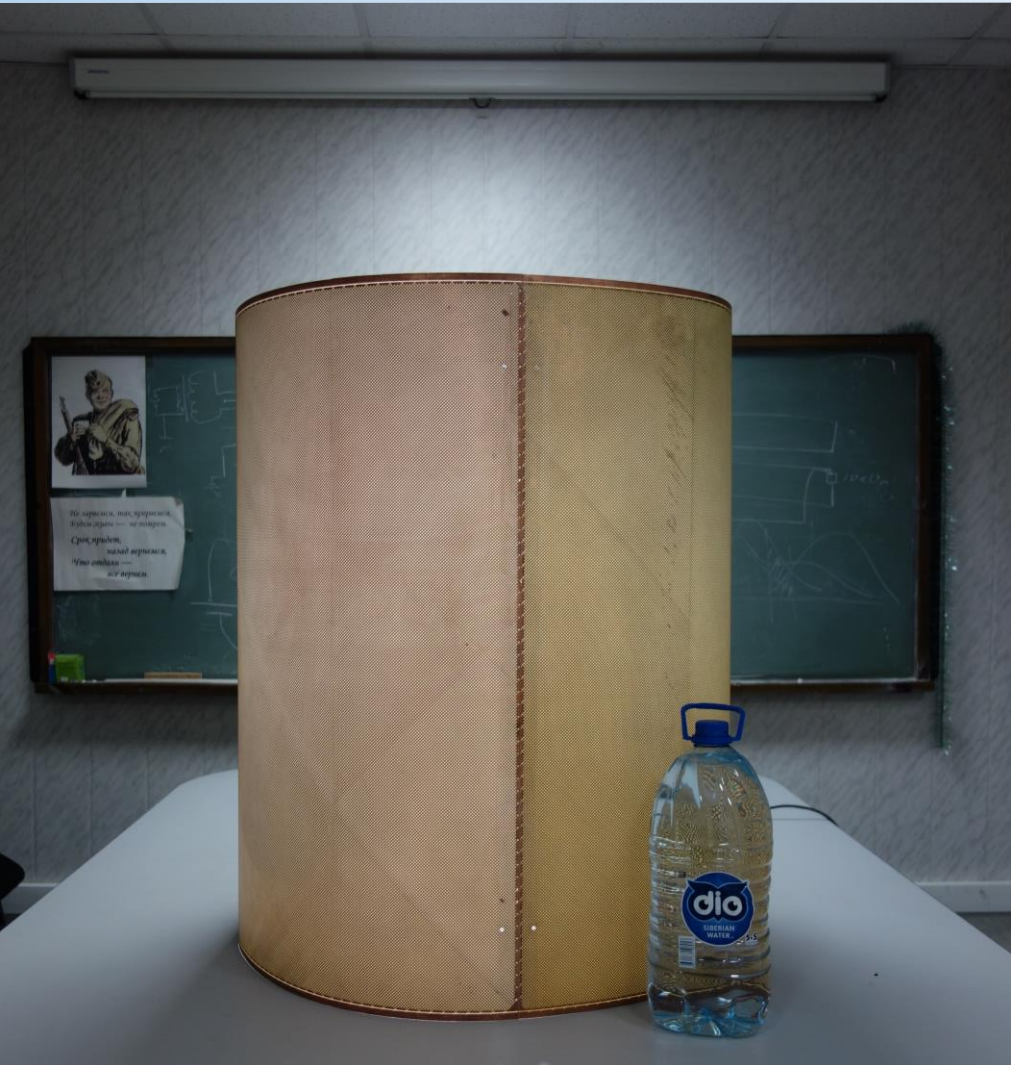

The cathode cylinder

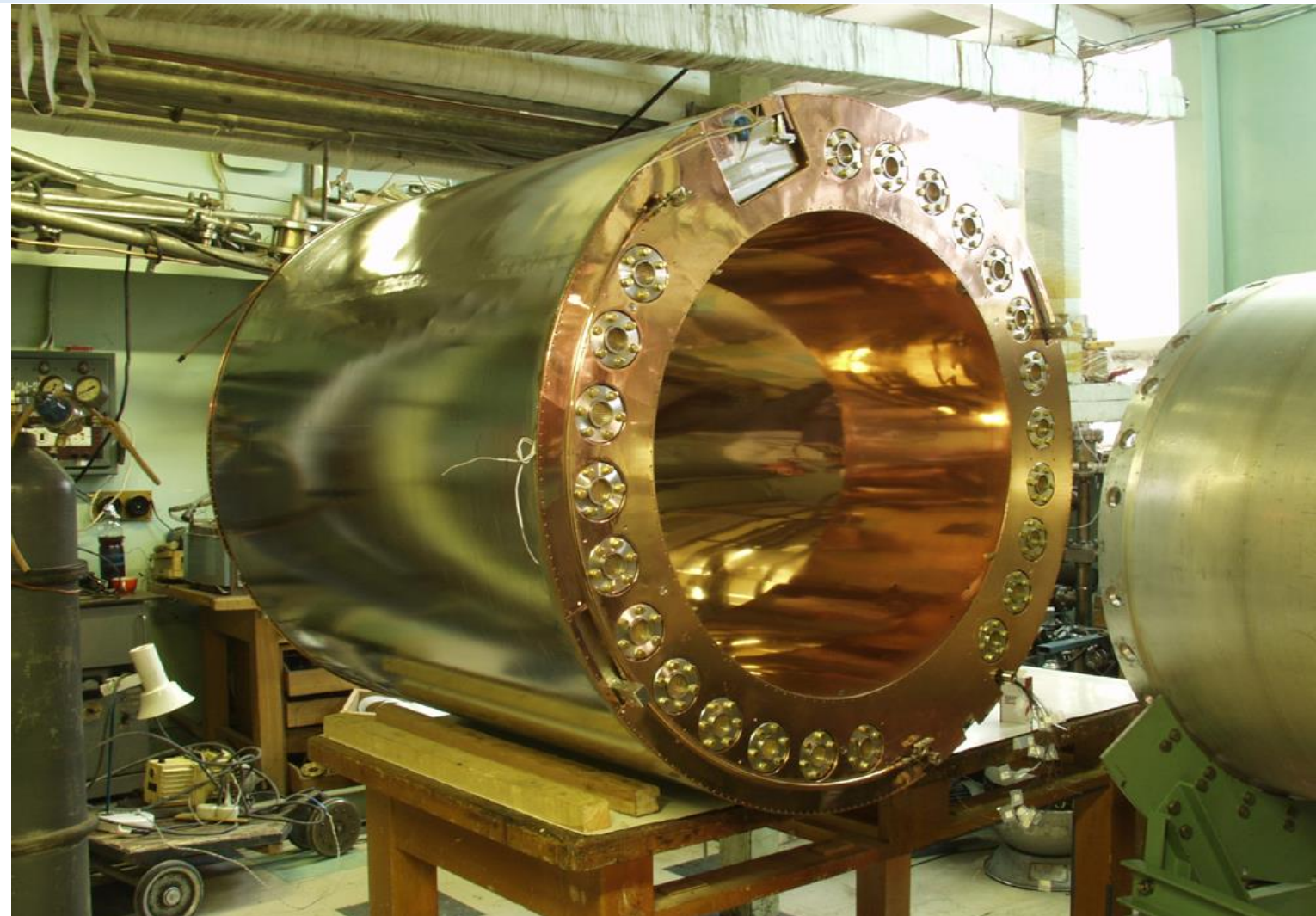

The assembled calorimeter vessel

# LXe cathode cylinder structure

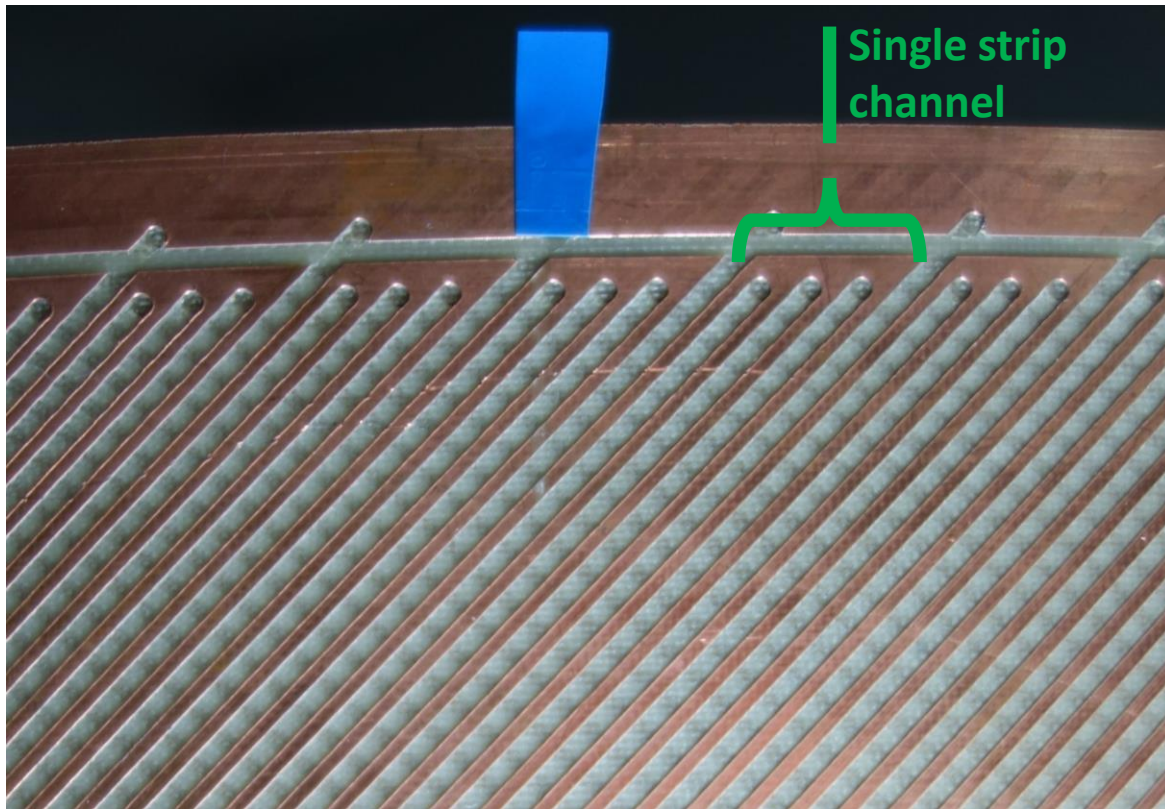

**Front light mode.** Splitted strips are seen well.

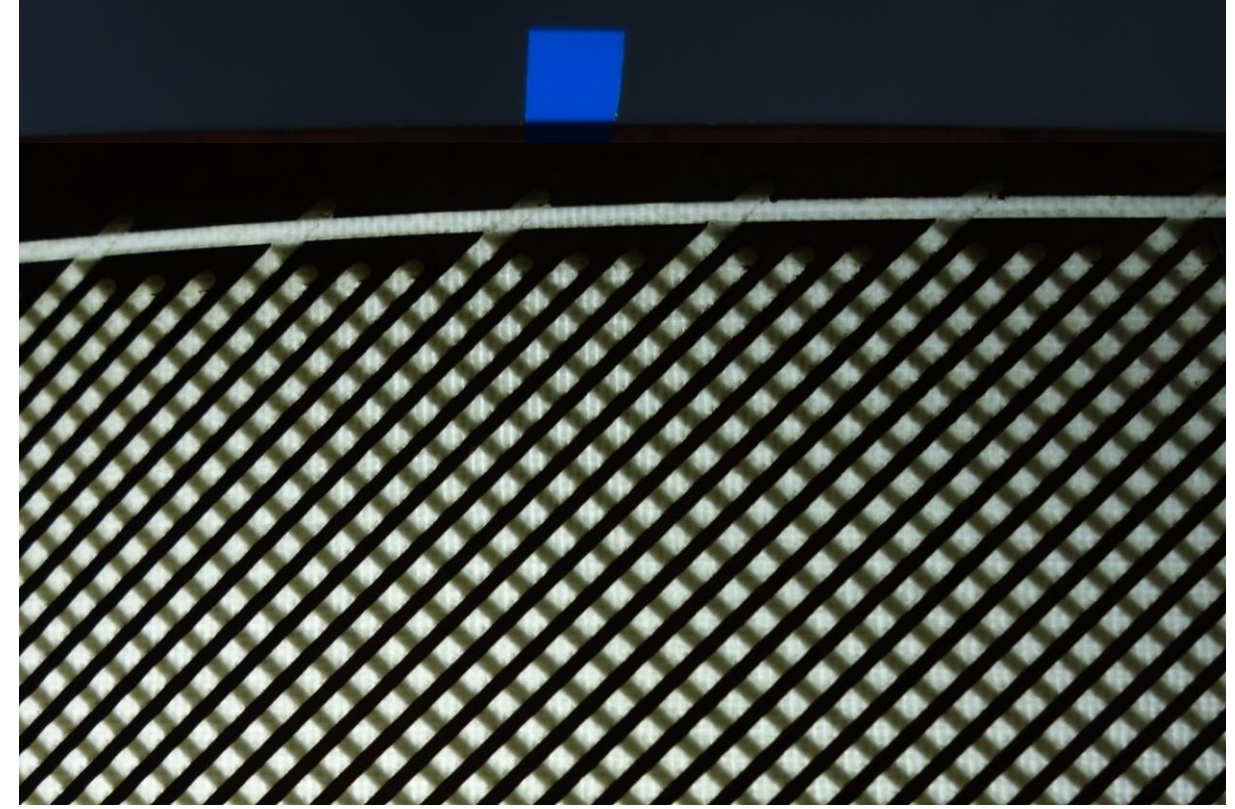

**Back light mode.** The strips on the *Dark Side of The Moon* back side of the cylinder are seen well through NEMA G10 0.5 mm layer.

Such semi-transparent electrode structure provides charge induction on both sides of cathode electrode. That allows one to determine both coordinates of photon conversion point using the information from one gap only. The coefficients of transparency are calculated from experimental and electrodynamics simulation data. The value is about 30 % and depends on gap number.

# LXe cryogenic system

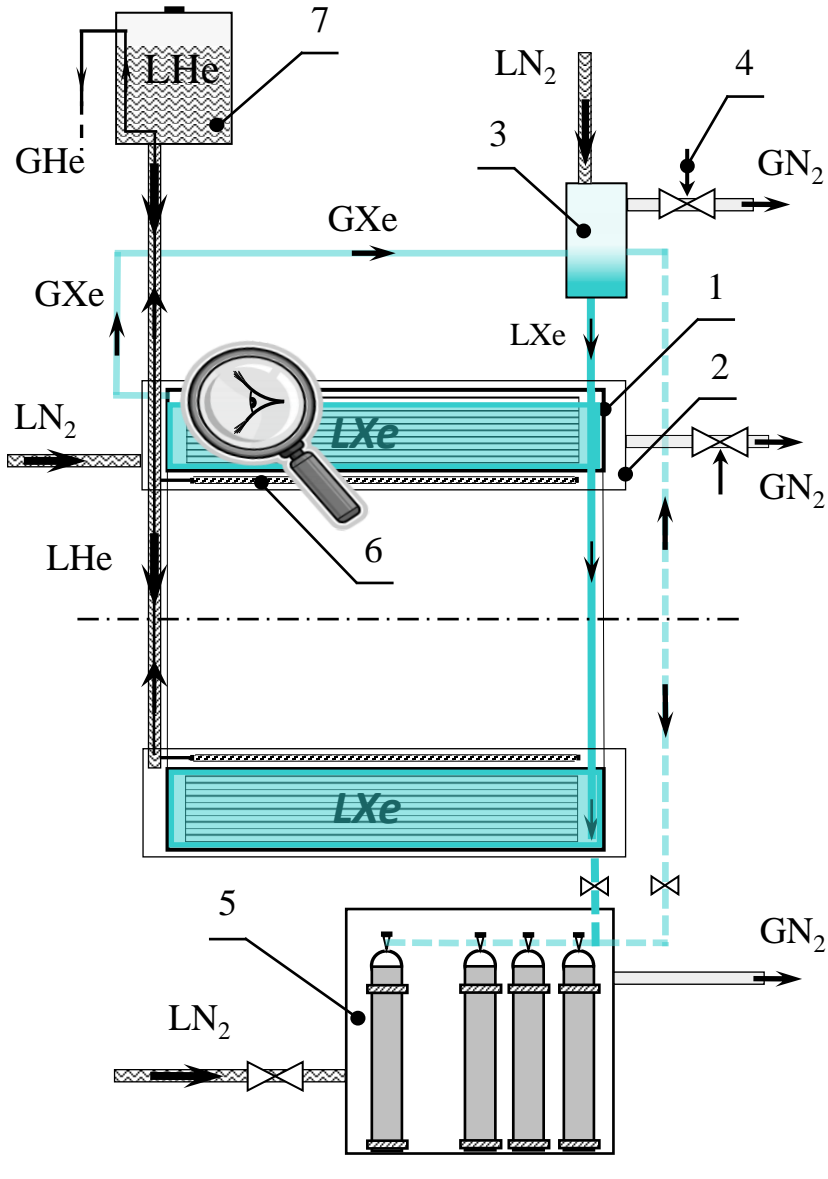

1. LXe calorimeter cylindrical stainless steel vessel
2. Common vacuum volume (calorimeter and solenoid)
3. Xenon liquefier (cooled with liquid nitrogen)
4. Pressure feedback electric valve (nitrogen flax)
5. Xenon storage
6. SC solenoid
7. Liquid Helium storage for SC solenoid

- Start-up time (Xenon filling) ~ 30 hours
- Draining time ~ 20 hours
- Liquid nitrogen consumption ~ 150 liters/day
- LXe temperature ~ 175K
- LXe pressure ~ 1.5 bar

The cryogenic system is quite simple and reliable. Thermodynamic parameters stability is provided by vapor pressure control. Temperature stability ~ 0.1 K.



*The underfilled gap ~ 1 cm is required in this very scheme. One needs the special LXe level control system for correct GEANT simulation.*

# Calorimeter electronics

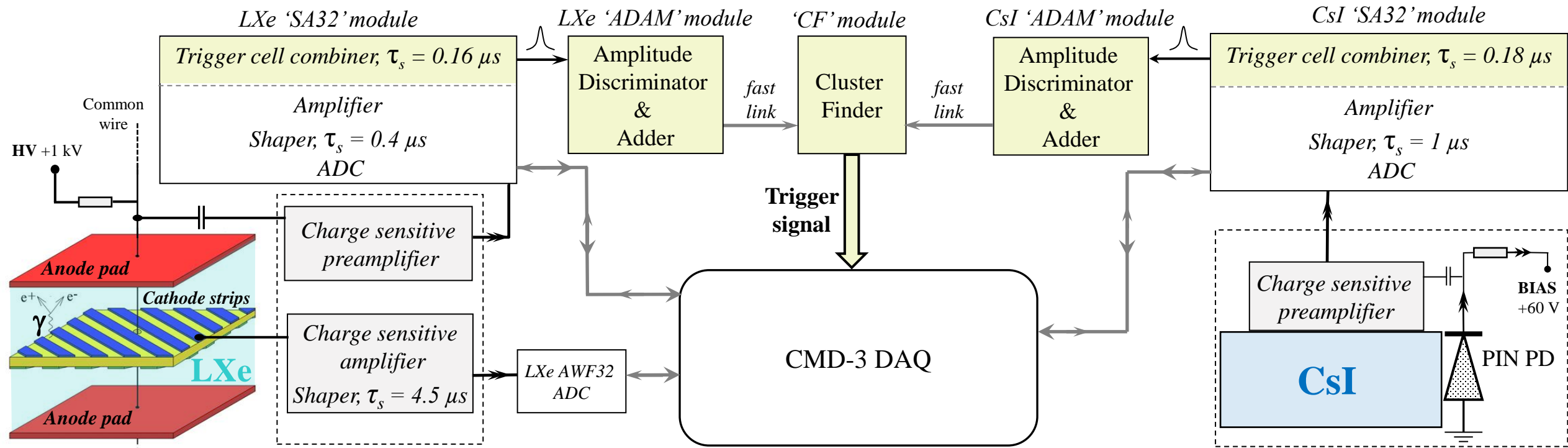

The detector operates in COMMON STOP mode

- CsI Counter noise  $\sim 0.5 \text{ MeV}$
- Anode channel noise:  $\sim 0.22 \text{ MeV}$
- Cathode channels noise:  $\sim 0.25 \text{ MeV}$
- Anode channel MIP amplitude:  $\sim 55 \text{ MeV}$

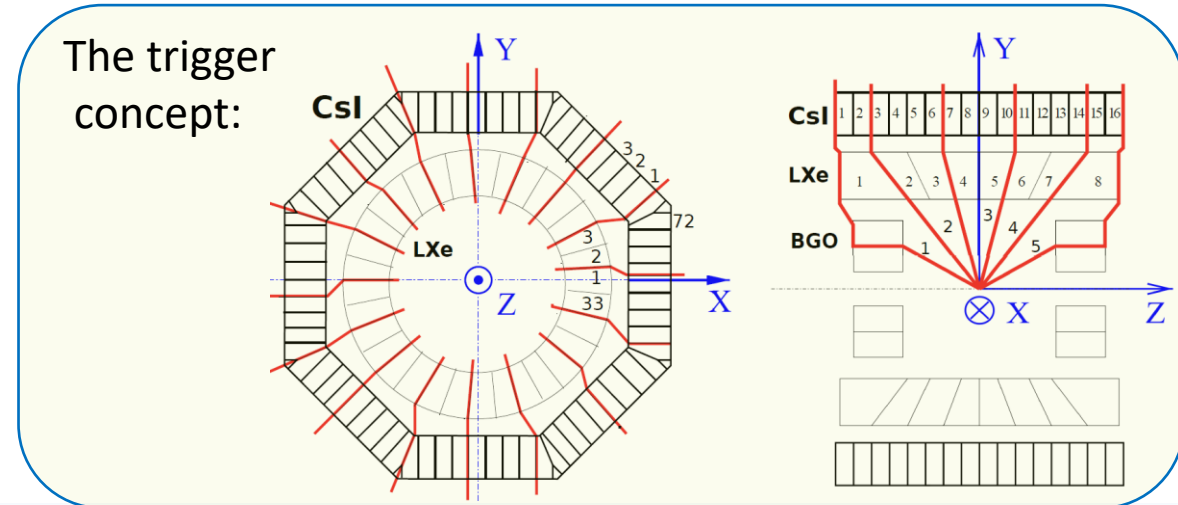

Combined LXe/Crystal calorimeter for low energy e+e- experiments

## Combined LXe/Crystal calorimeter main parameters:

- *Solid angle:*  $0.8 \times 4\pi$
- *Thickness of composite calorimeter:*  $\sim 13.5 X_0$
- *Total material in front of active part:*  $0.35 X_0$  (6.27 g/cm<sup>2</sup>)
- *Total material between LXe and CsI :*  $0.25 X_0$  (4.63 g/cm<sup>2</sup>)
- *Spatial resolution for the photon conversion point:*  $\sim 2\text{mm}$
- *Spatial resolution for the cosmic muons tracks:*  $\sim 1.5 - 2\text{mm}$
- *Energy resolution for 0.2 ÷ 1GeV electrons :*  $8 \div 4\%$

# Strips (LXe coordinate system) calibration

The coordinate system calibration is realized with cosmic muon tracks.

Cluster coordinate  $x$  is calculating with the following equation :

$x = x_i \cdot q_i \cdot f(q_i, x_i) / \sum q_i$ , where  $\mathbf{X}$  – local axis transverse to strips,  $x_i$  – strip coordinate,  $q_i$  – strip signal amplitude (measured charge),  $i$  – strip number,  $f(q_i, x_i)$  – *weight* function, calculated from electrodynamics simulation.

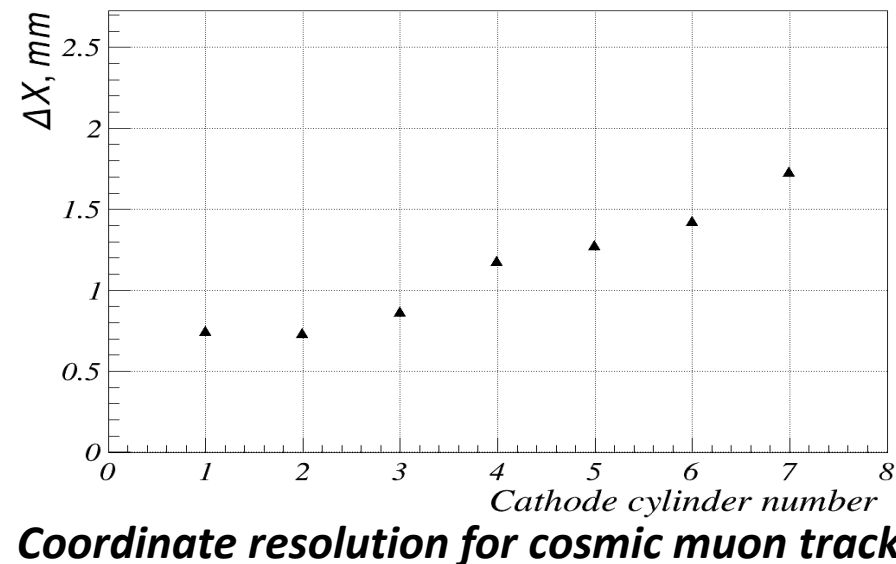
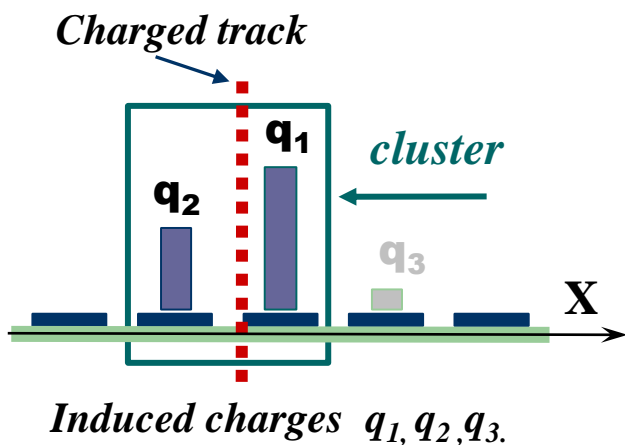

## Cosmic muon event in the CMD-3

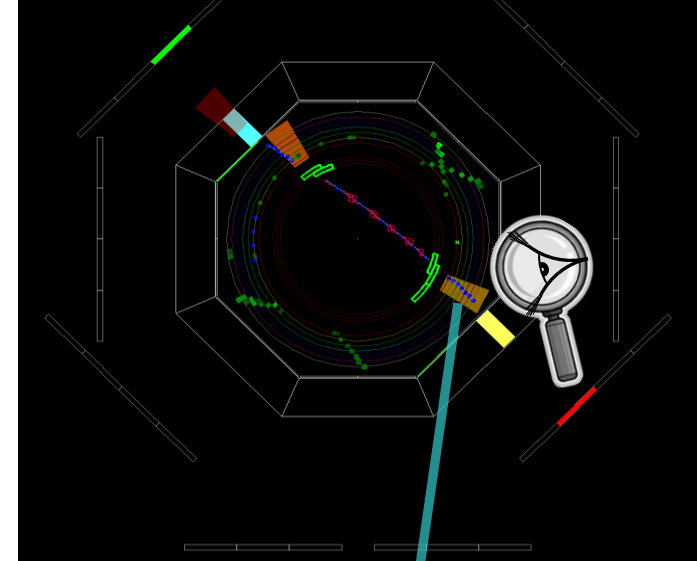

## Cosmic muon track in the LXe

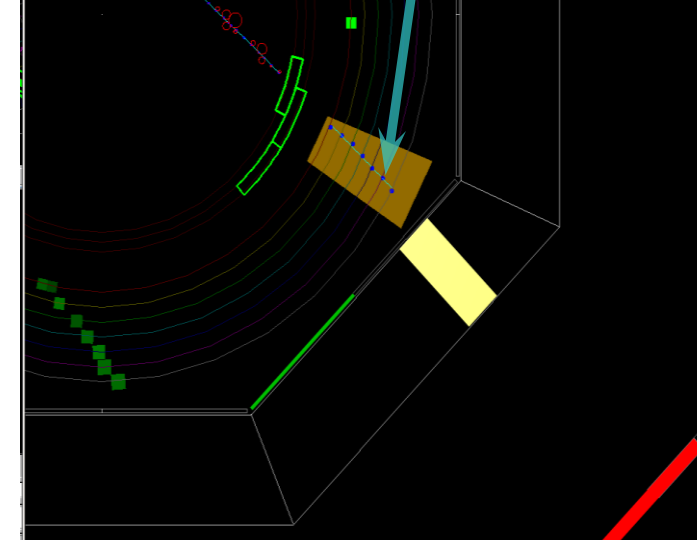

# Combined calorimeter calibration concept

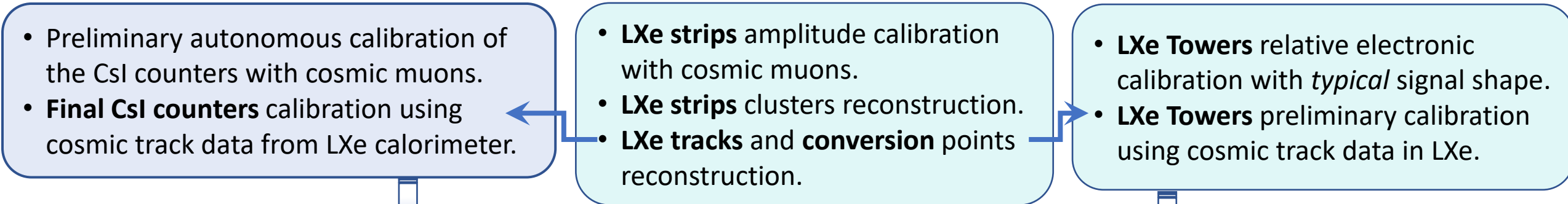

- Towers clusters reconstruction.
- LXe Towers cluster and conversion points adjustment.
- Joined LXe-CsI cluster reconstruction.
- Unsewn CsI cluster reconstruction.
- Final LXe towers calibration with elastic e+e- experimental data by minimizing the functional:

$$\chi^2 = \sum_{k=1}^N \frac{\left( E_{sim}^k(\theta, \varphi) - \sum_{i=1}^n E_i^k g_i - E_{CsI}^k \right)^2}{\sigma_{sim}^2(\theta)} \rightarrow \min,$$

$k$  – event number,  $N$  – total number of  $e^+e^-$  events,  $E_{sim}^k(\theta, \varphi)$  – simulated energy deposition in composite calorimeter for particle moving at an angle of  $\theta, \varphi$  from interactions point,  $\sigma_{sim}^2(\theta)$  – simulated energy dispersion,  $E_i^k$  – amplitude in  $i$ -th tower channel,  $E_{CsI}^k$  – energy deposition in CsI (calibrated with cosmic muons),  $g_i$  – calibration coefficient for  $i$ -th tower channel,  $n$  – number of towers in cluster.

Repeat until calibration coefficients convergence ...

# Combined LXe/Crystal calorimeter performance:

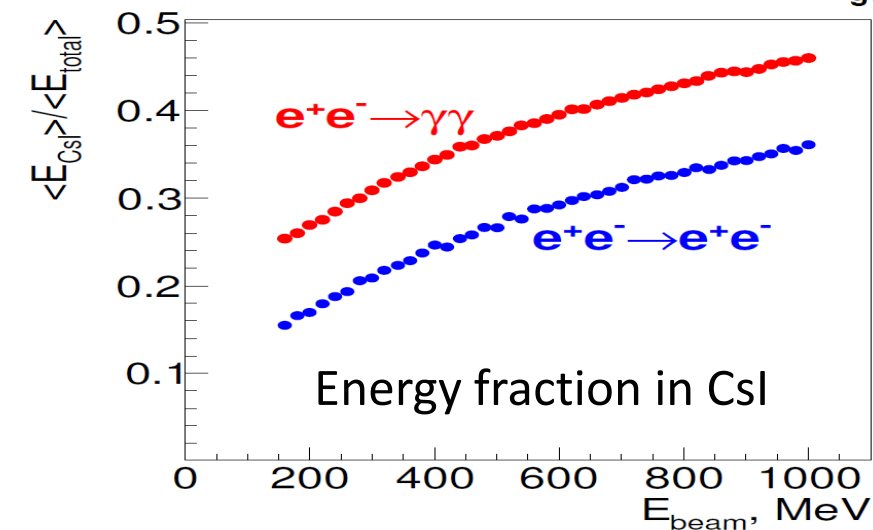
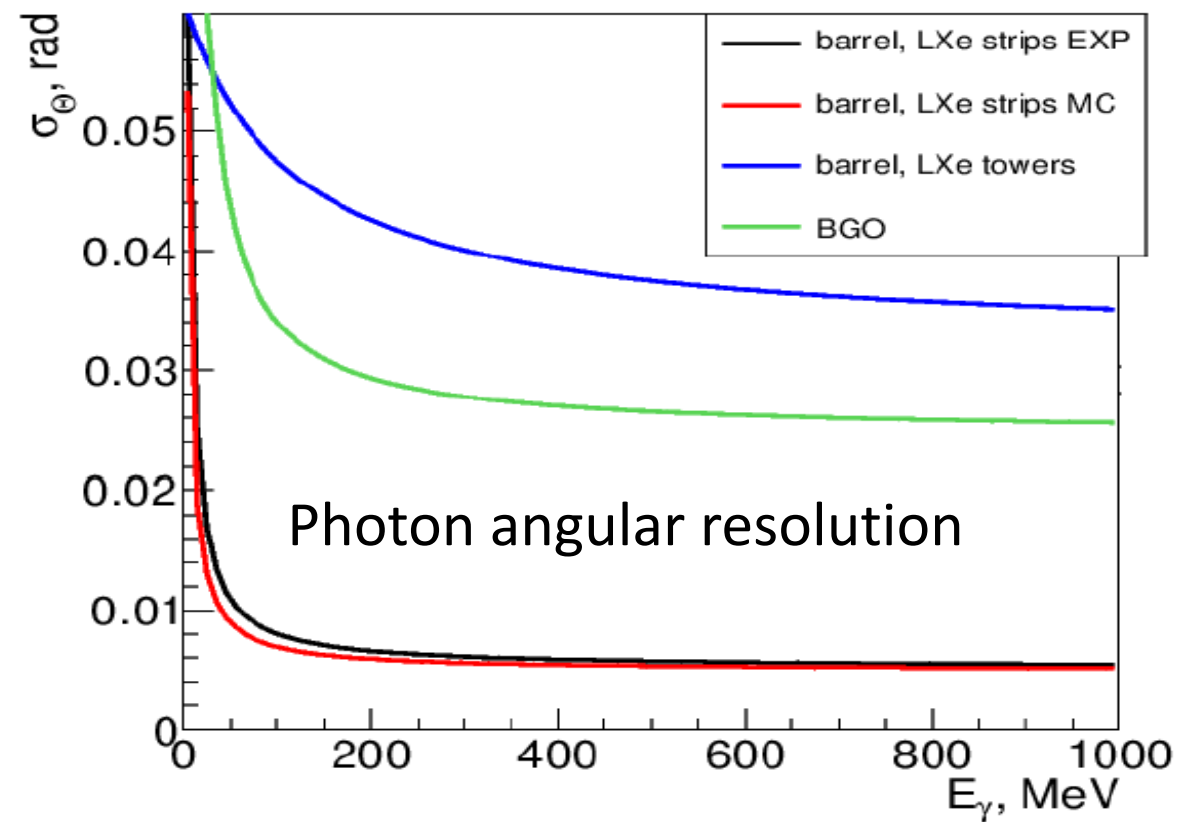
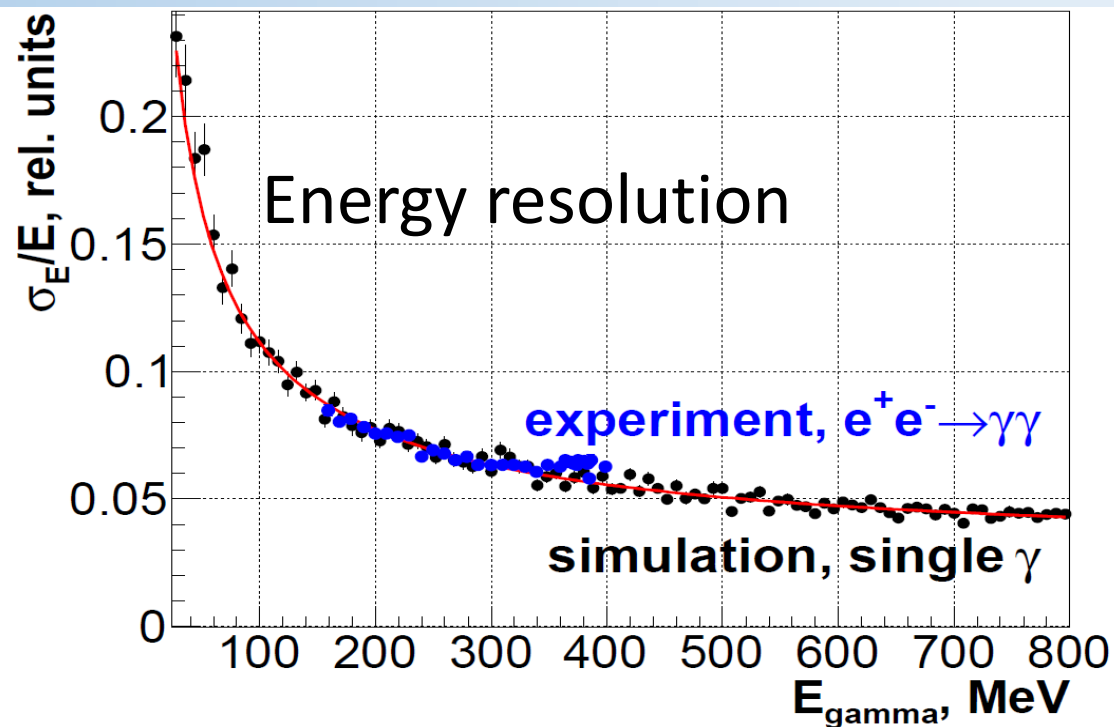

# Combined LXe/Crystal calorimeter performance:

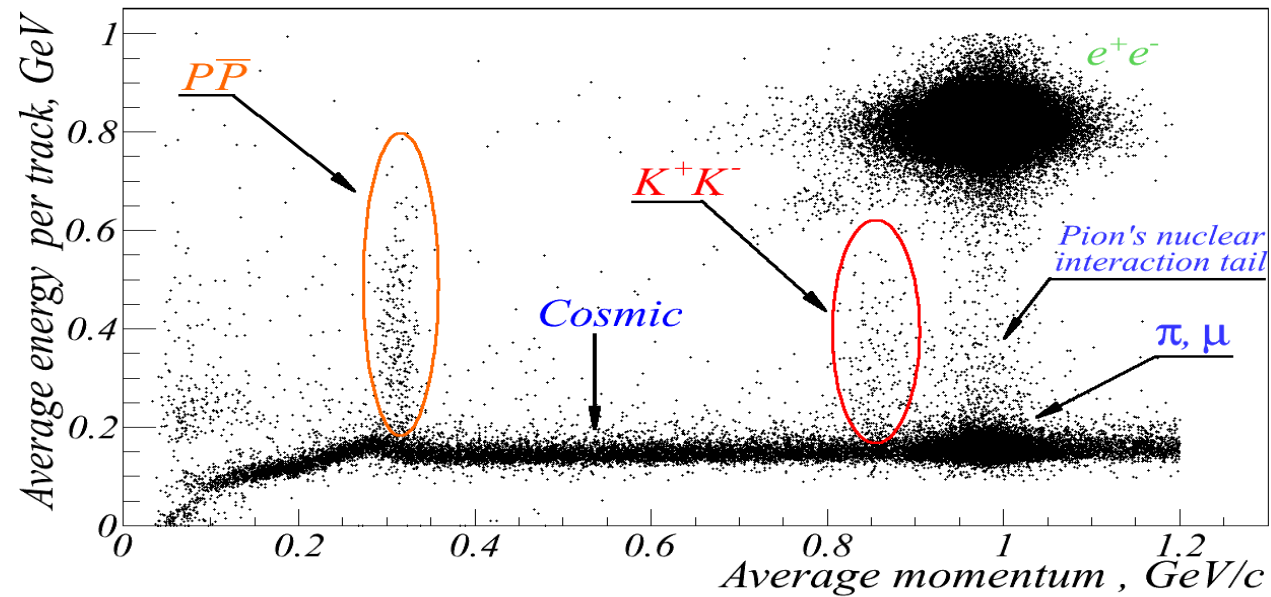
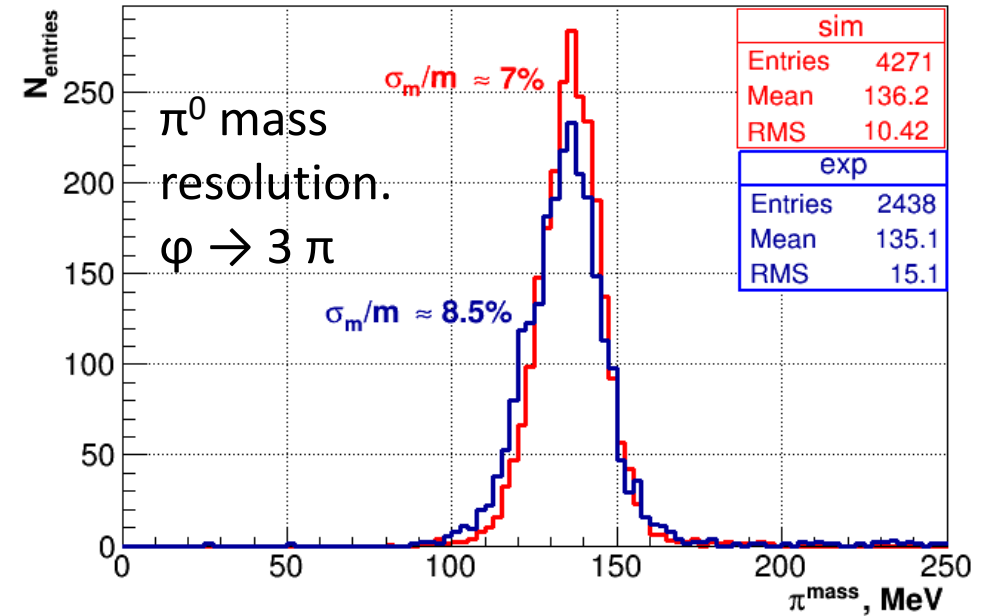
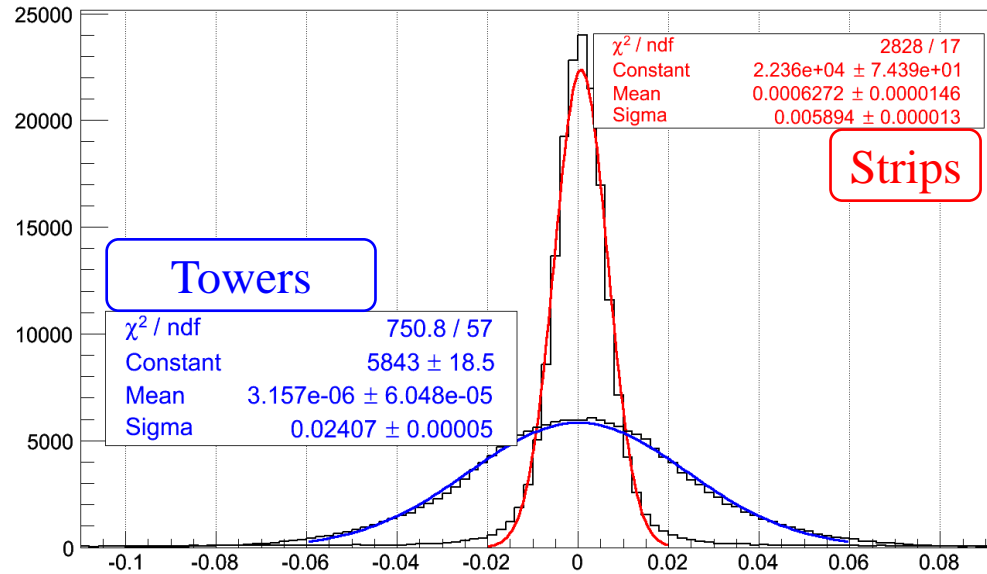

# LXe $dE/dx$ particle identification (PID)

- The boosted decision trees (**BDT**) method provided by the **TMVA** package is used.
- For each track in the DC reaching LXe the six values of the responses of BDT classifiers are calculated:  
 $BDT(e^\pm, \mu^\pm)$ ,  $BDT(e^\pm, \pi^\pm)$ ,  $BDT(e^\pm, K^\pm)$ ,  $BDT(\mu^\pm, \pi^\pm)$ ,  $BDT(\mu^\pm, K^\pm)$ ,  $BDT(\pi^\pm, K^\pm)$
- Each classifier are trained for optimal separation for pairs of particle types in certain range of the momentum  $P$  and  $dLXe$  - expected path length of the particle in the gap, estimated via the DC-track extrapolation (equivalent to  $\theta$ - $\varphi$  of input DC track).
- The input variables for the classifiers are the  $dE/dX$  values in the **12** LXe gaps.
- Since this PID method is based on the precise measurement of the energy deposition for different type of particles the strip channels of the LXe calorimeter were accurately calibrated, and the simulation was tuned to reach a good agreement between experiment and simulation

More details : “Charged particle identification using the liquid Xenon calorimeter of the CMD-3 detector”.

V.I. Ivanov et al. <https://inspirehep.net/literature/1811676> Aug 12, 2020

# LXe $dE/dx$ particle identification (PID)

The  $dE/dx$  spectra examples for electrons ( $E_{\text{beam}} \sim 900$  MeV) and muons in different gaps:

- - Experiment
- - Simulation
- - Tuned simulation

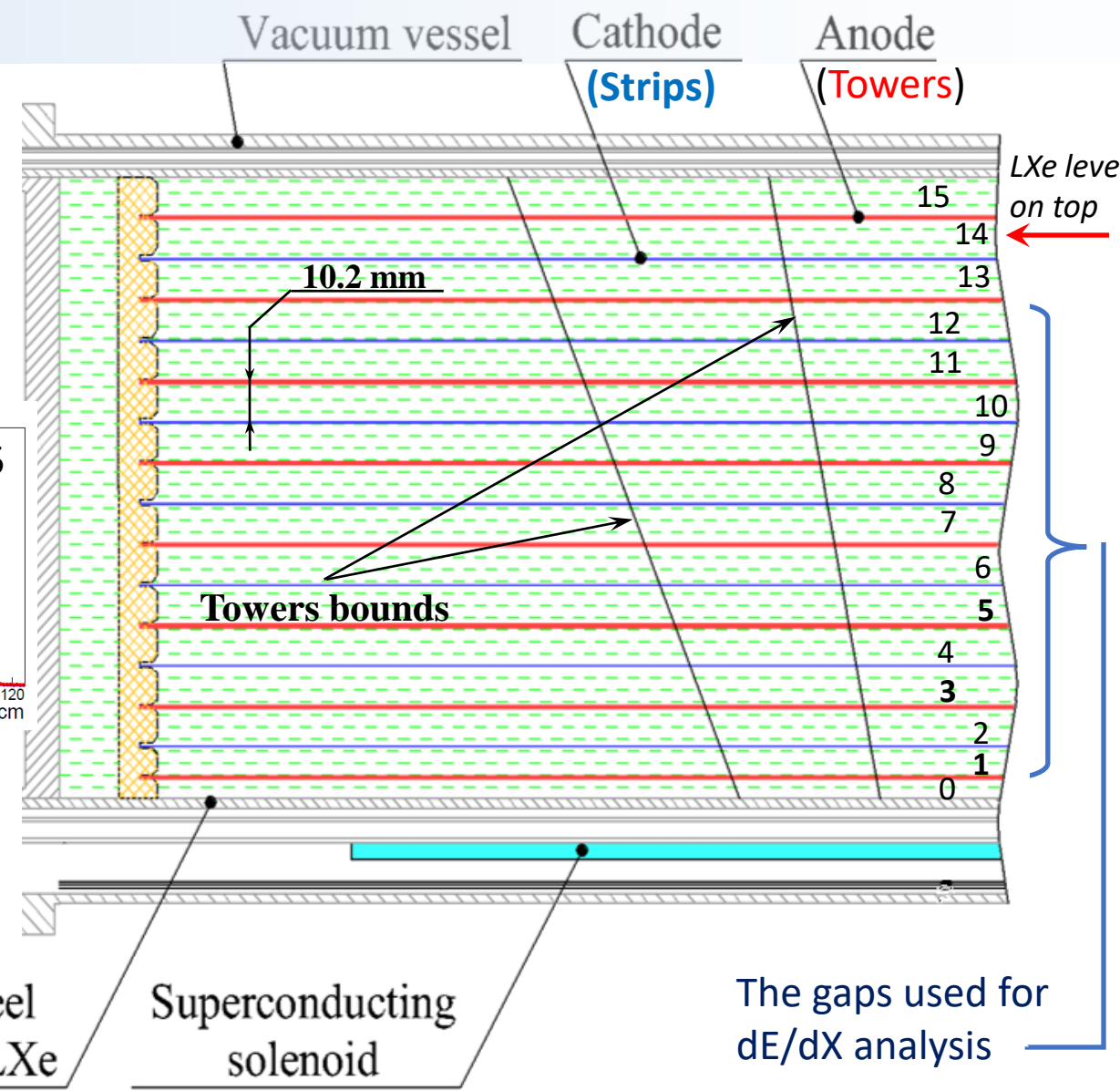
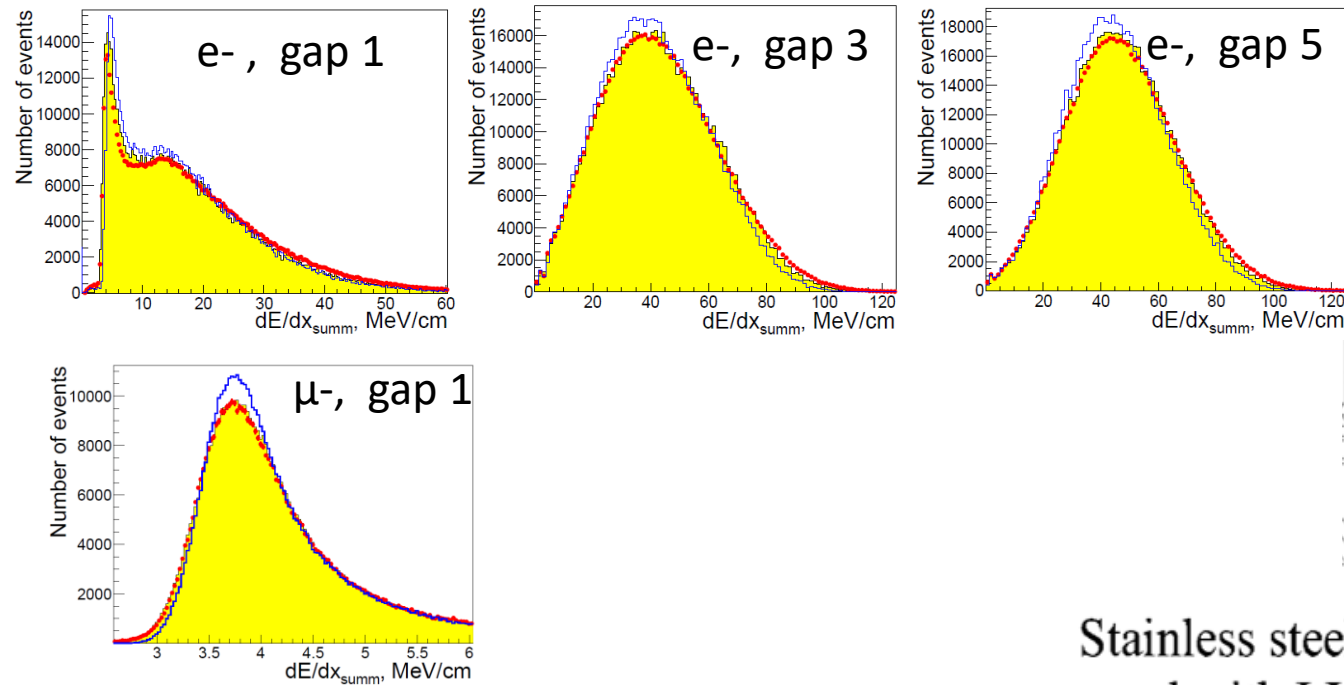

# Example of LXe $dE/dx$ $e/\pi$ separation

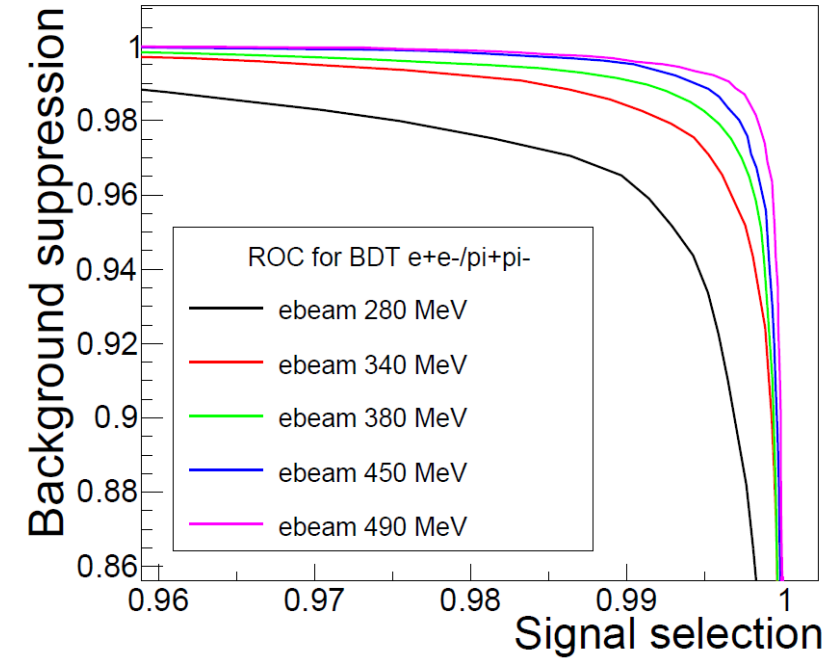
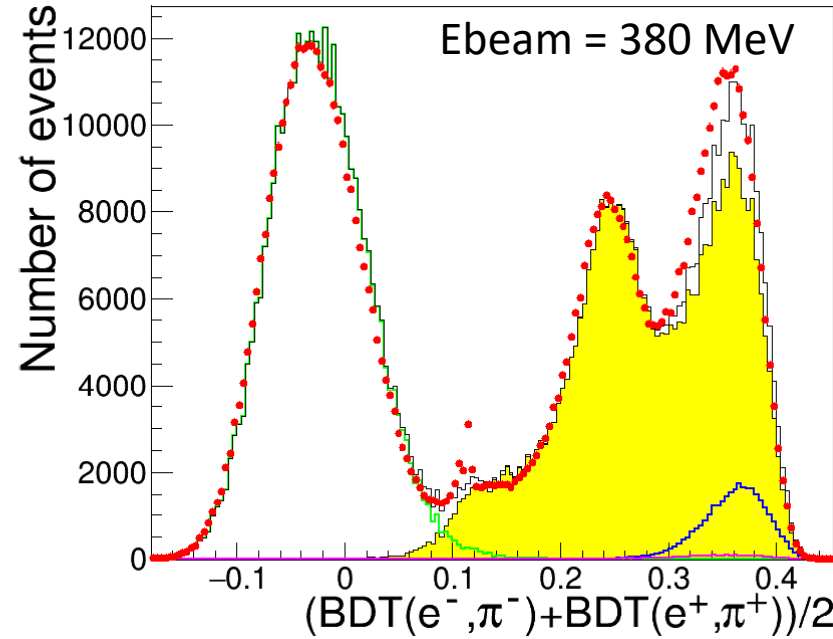
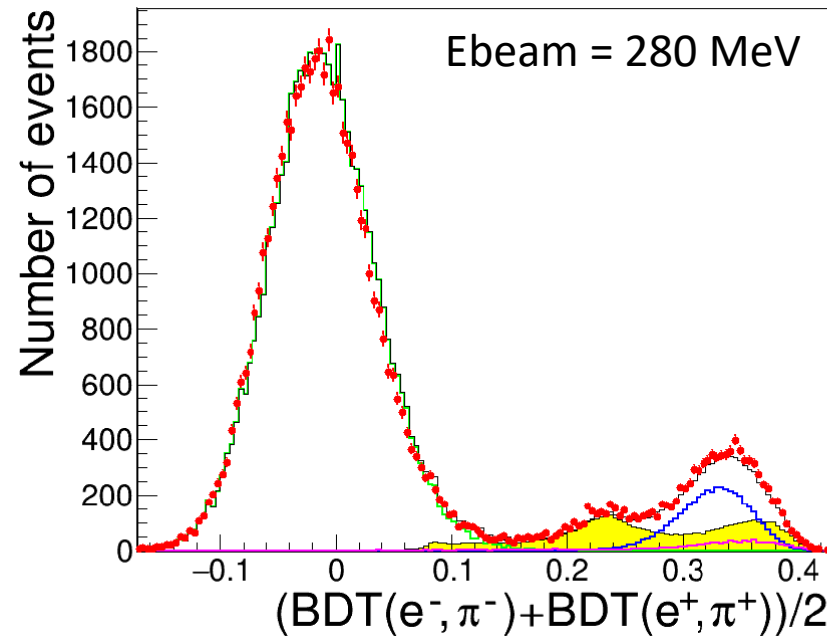

Average for to collinear tracks classifier distribution:

- - Experiment
- - Simulation of the  $\pi^+ \pi^-$  ( $\gamma$ )
- - Simulation of the  $e^+e^-$  ( $\gamma$ )
- - Simulation  $\mu^+ \mu^-$  ( $\gamma$ )
- - Simulation of cosmic muons
- - Simulation of full signal+background spectrum

Receiver operating characteristic for BDT  $e^+e^-/\pi^+\pi^-$  for different beam energies.

The operating of the LXe calorimeter during experimental runs showed that its parameters are close to the design values. The procedure of  $dE/dX$  particle identification was successfully developed in 2020 year.

After to 1-2 years we expect detector upgrade. The barrel calorimeter upgrade is also in our plans...

*Thank you for attention !*



# Conclusion

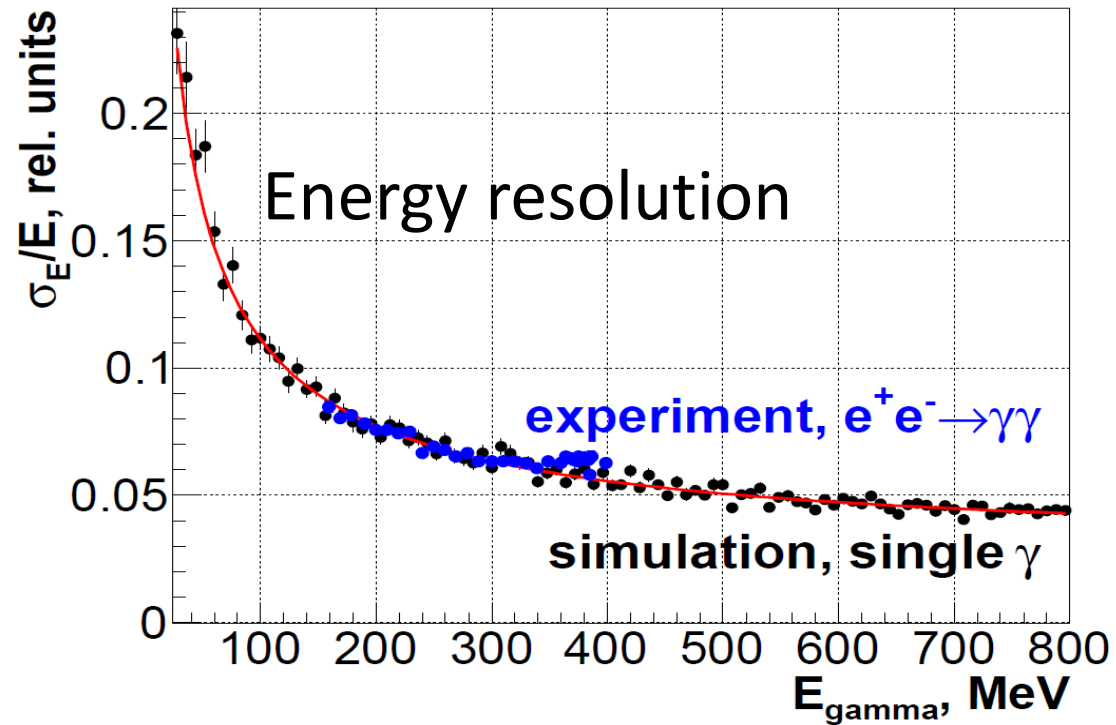

Passive material between calorimeters  $0.25X_0$

Stainless steel to aluminum alloy ->  
 $\sim 5\%$  of resolution at 200 MeV

## 2: Main parameters:

- LXe volume: 400 liters (1200 kg)
- Solid angle:  $\sim 0.8 \times 4\pi$
- Thickness : 15 cm :  $5.4 X_0$
- Thickness of composite calorimeter:  $\sim 13.5 X_0$
- Total material in front of active part:  $0.35 X_0$  ( $6.27 \text{ g/cm}^2$ )
- Total material between LXe and CsI :  $0.25 X_0$  ( $4.63 \text{ g/cm}^2$ )
- Number of electronics channels: 2112 + 264
- Anode channels sensitivity:  $\sim 14\,000 \text{ el./MeV}$
- Anode channels noise:  $\sim 3000 \text{ e}$  ( $0.22 \text{ MeV}$ )
- Cathode channels MIP amplitude:  $\sim 36\,000 \text{ e}$
- Cathode channels noise:  $\sim 2000 \text{ e}$
- The value of electric field in the gap:  $E \sim 1.1 \text{ kV/cm}$
- Full drift time of ionization electrons in the gap:  $4.5 \mu\text{s}$
- Attenuation length of electrons:  $\sim 15 - 20 \text{ mm}$ .
- Charge lost due recombination:  $\sim 20\%$  (for MIP)
- Start-up time (Xenon filling):  $\sim 30 \text{ hours}$
- Draining time:  $\sim 20 \text{ hours}$
- Liquid nitrogen consumption:  $\sim 150 \text{ liters/day}$
- LXe operating temperature:  $\sim 175 \text{ K}$
- LXe operating pressure:  $\sim 1.6 \text{ bar}$

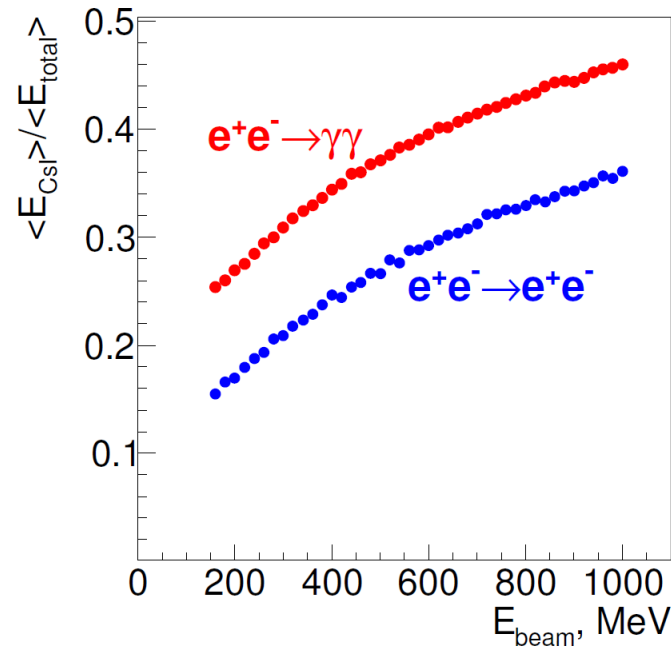
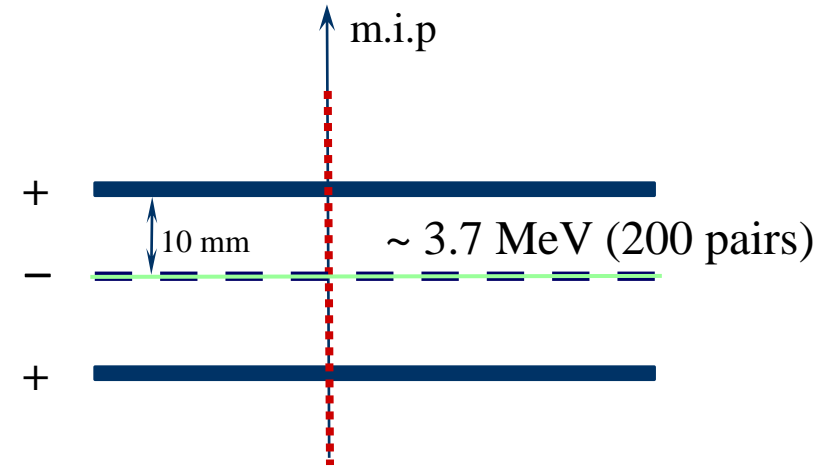

- ✓ Average light output of counters:  
5000 CsI(Tl) ph.e/MeV  
2800 CsI(Na) ph.e/MeV
- ✓ Noise:  $\leq 0.5 \text{ MeV}$

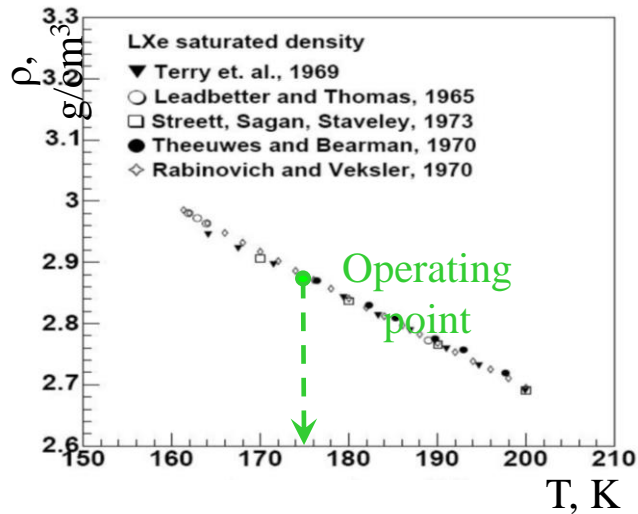

8: LXe density VS temperature

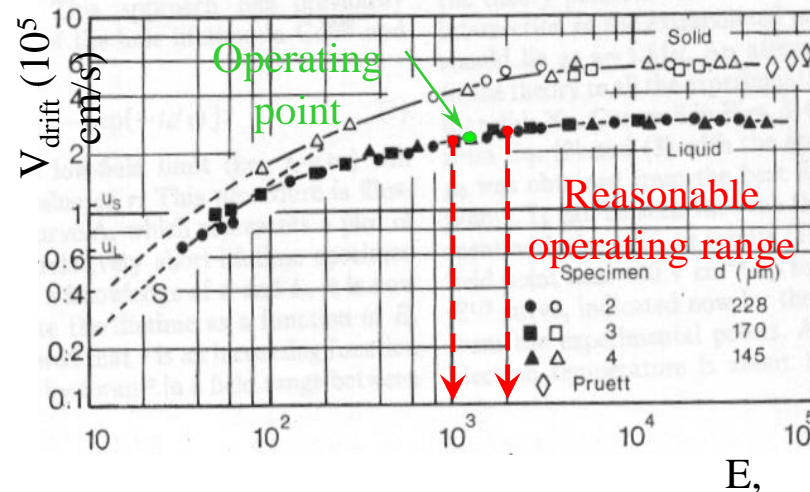

9: Electron drift velocity VS electric field

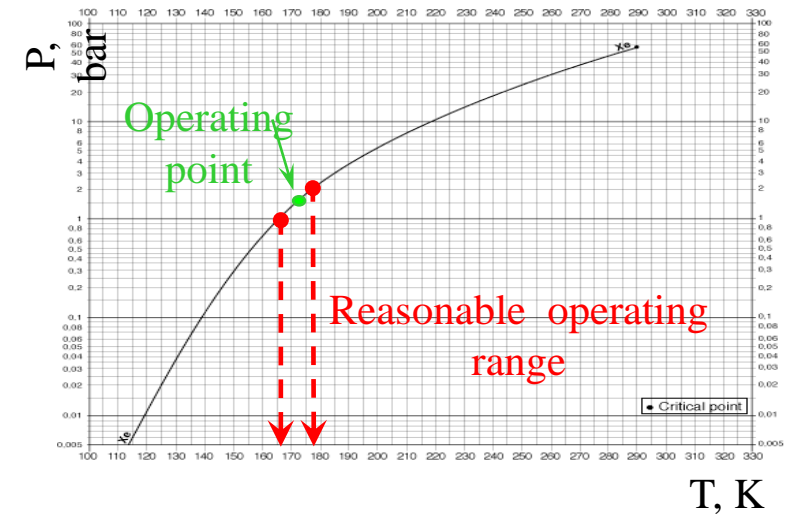

10 : LXe vapor pressure VS temperature

**Calorimeter operation parameters:**

- Start-up time (Xenon filling) ~ 30 hours
- Draining time ~ 20 hours
- Liquid nitrogen consumption ~ 150 liters/day
- LXe temperature ~ 175K
- LXe pressure ~ 1.5 bar

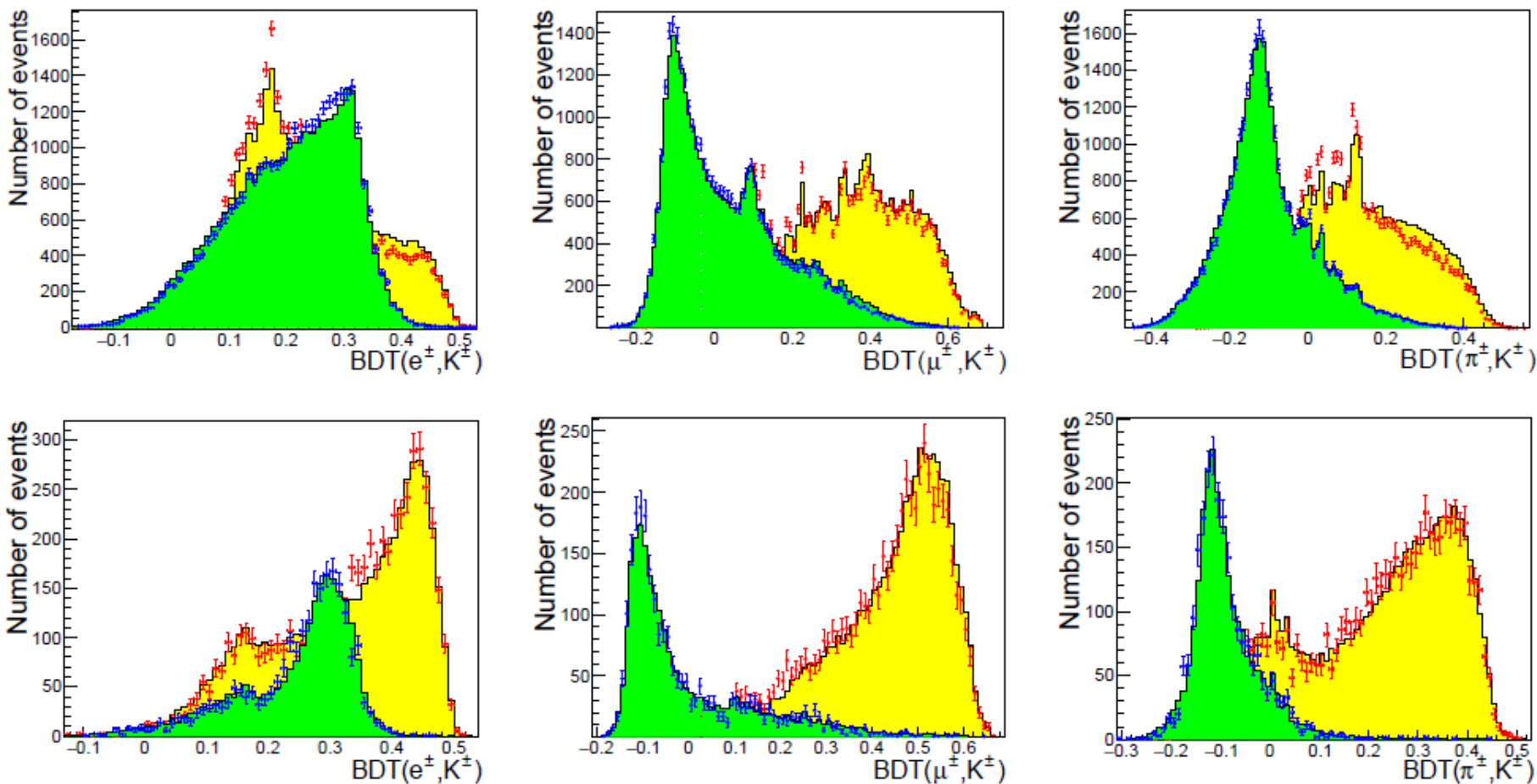

Рисунок 2.42 — Спектры  $\text{BDT}(e^\pm, K^\pm)$  (слева),  $\text{BDT}(\mu^\pm, K^\pm)$  (посередине) и  $\text{BDT}(\pi^\pm, K^\pm)$  (справа) для  $K^\pm$  и  $\pi^\pm$  отобранных из событий процесса  $e^+e^- \rightarrow K^+K^-\pi^+\pi^-$  в эксперименте (красные маркеры для  $K^\pm$  и синие для  $\pi^\pm$ ) и моделировании (желтая гистограмма для  $K^\pm$  и зеленая для  $\pi^\pm$ ). Верхние картинki построены для частиц с импульсами больше 100 МэВ, нижние — больше 450 МэВ. Используются все данные из заходов 2019-го года.

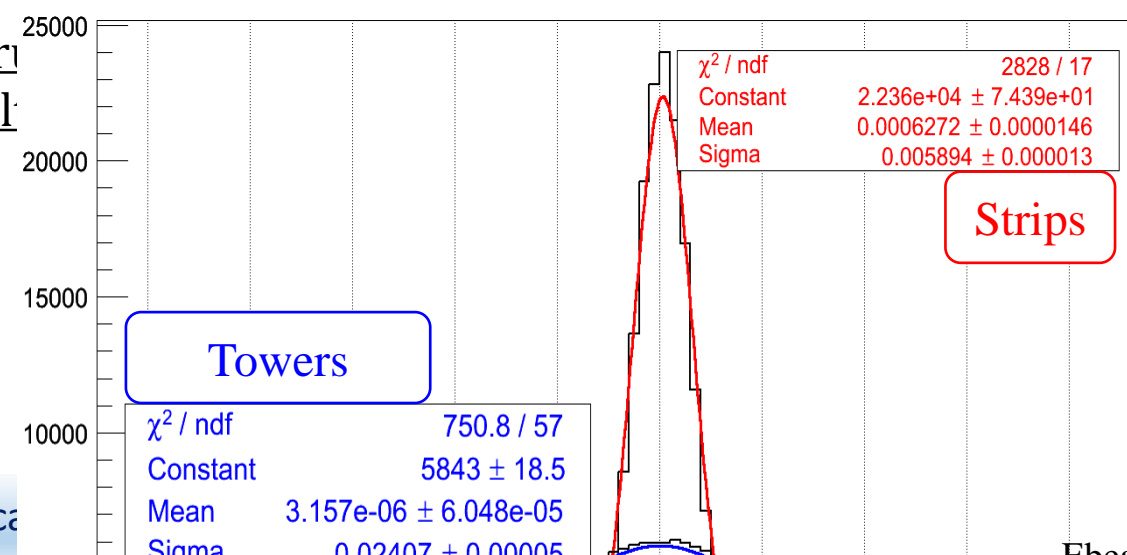
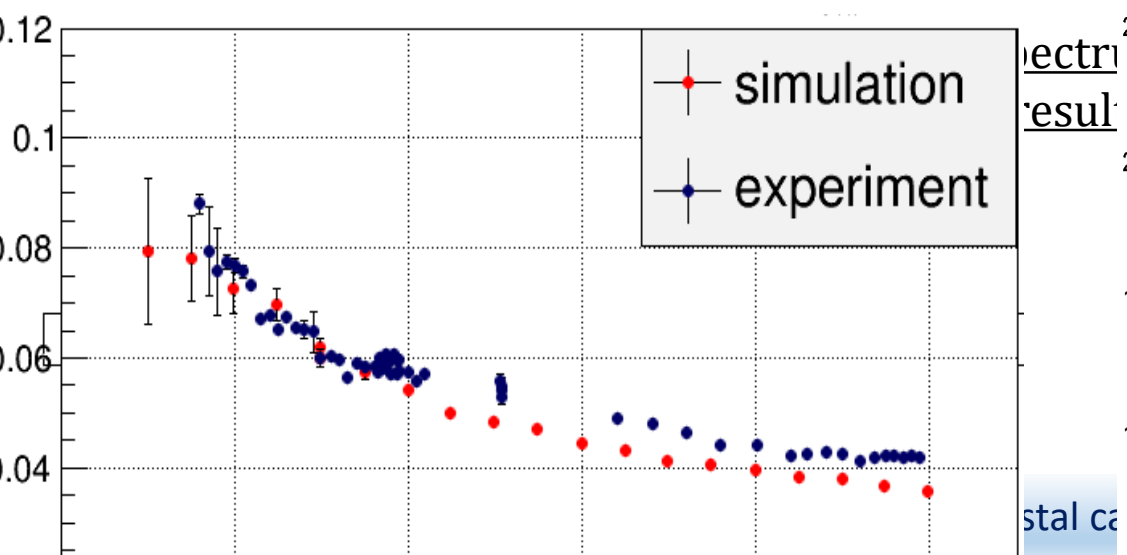
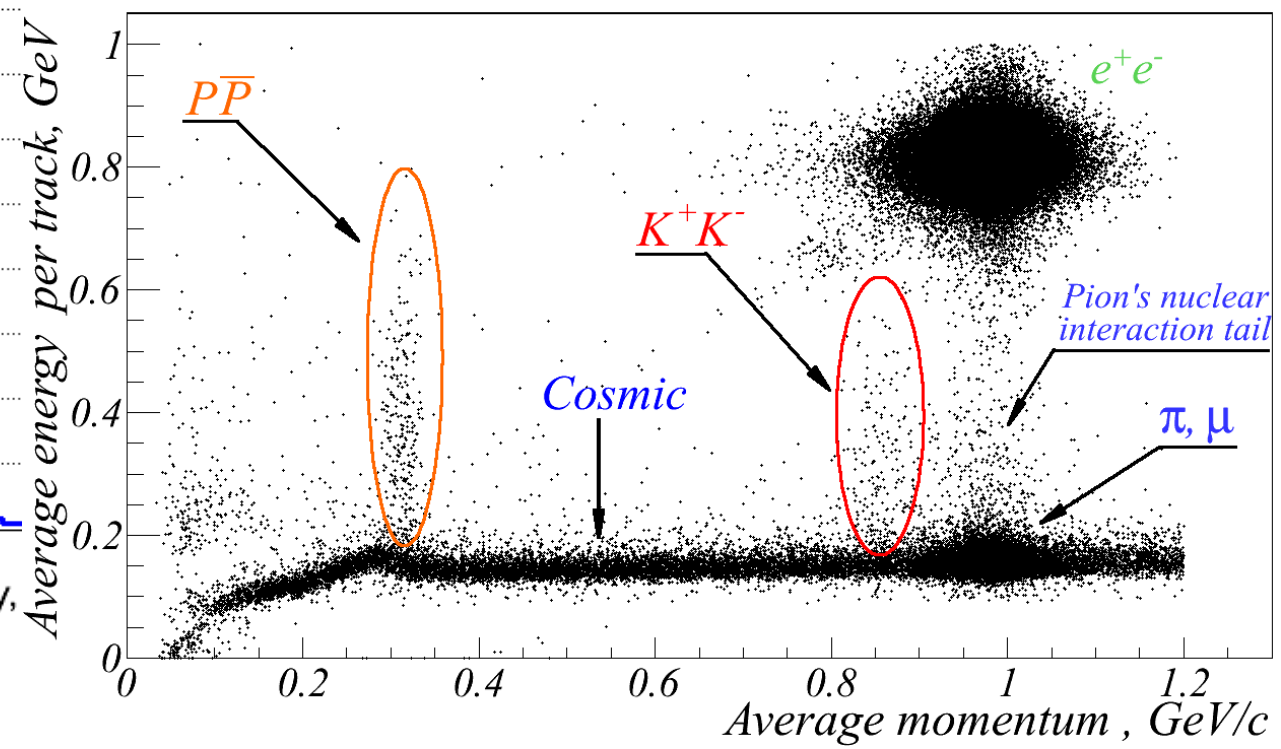
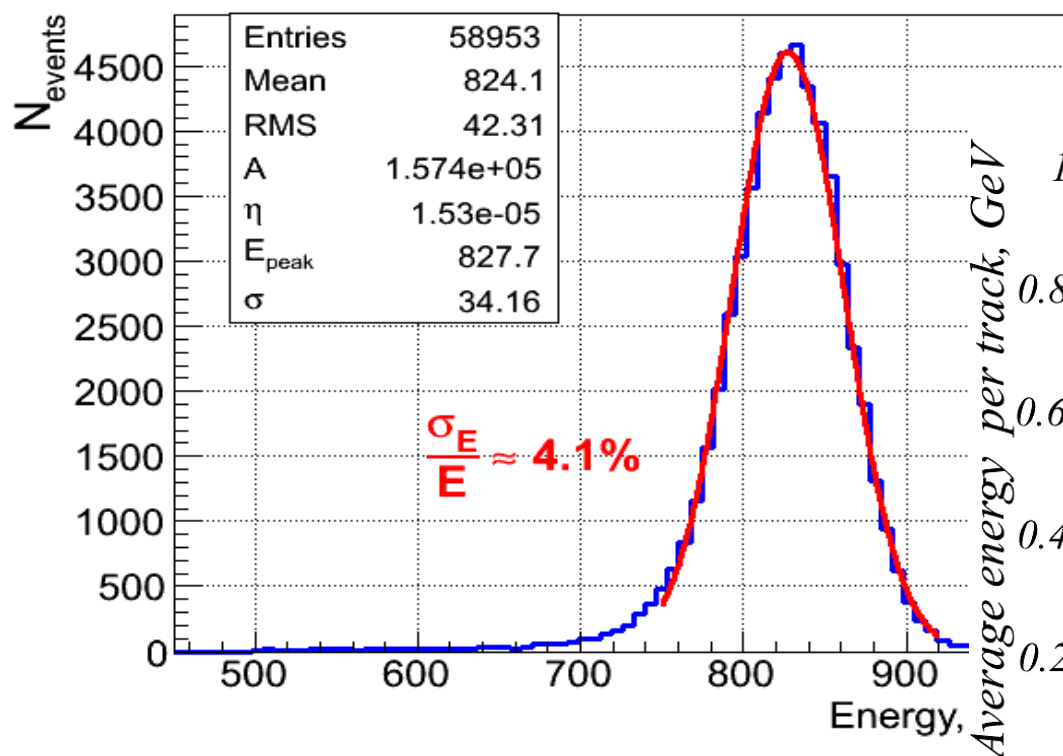

1 LXe layer  
ons.

$E_{\text{beam}} = 900 \text{ MeV}$