

# Longitudinal Electron Energy Distribution Measurements in PR-2 Mirror Machine

Dobrynya Kolodko<sup>a)</sup>, Ivan Sorokin and Igor Vizgalov

*National Research Nuclear University MEPhI 115409, Russia, Moscow, Kashirskoe highway, 31*

<sup>a)</sup>Corresponding author: dv.kolodko@plasma.mephi.ru

**Abstract.** A grid energy analyzer of electrons has been designed and assembled for linear plasma device PR-2. That analyzer is used for measurements of the longitudinal electrons energy distribution function (EEDF) of the beam-plasma discharge and can detect energy up to 10 keV. The EEDF obtained for various accelerating voltage of the electron gun 600–1500, while a pressure and an emission current of the electron gun during the experiments were fixed. Two modes of the beam-plasma discharge were observed depending on accelerating voltage of electron beam gun. Considerable fraction of electrons has energy exceeding the beam energy due to the beam-plasma interaction.

## INTRODUCTION

Beam-plasma discharge is used in PR-2 mirror machine (Fig.1) [1]. Due to plasma parameters can be varied in a wide range. For better understanding of the instabilities processes it is important to know longitudinal electron energy distribution. Precise definition of electron energy distribution function allows interpreting Langmuir probe characteristics in more accurate way. In addition, it allows understanding processes in auto-oscillating regime in plasma-surface interaction [1, 2].

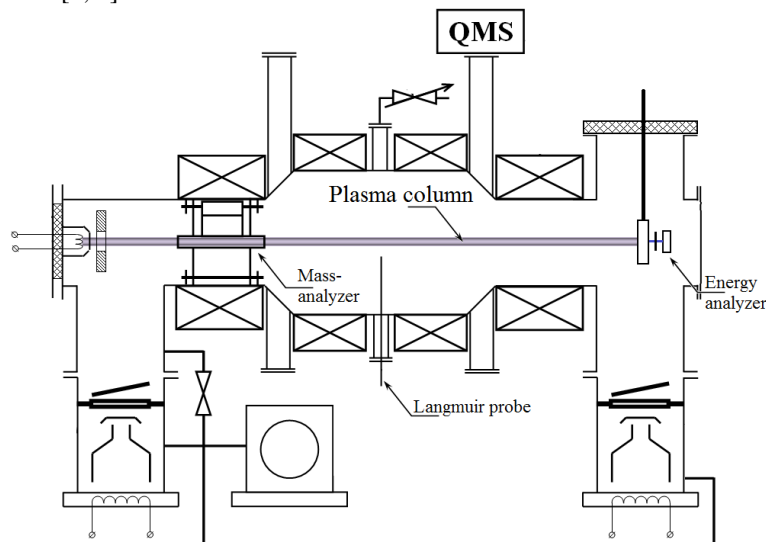

FIGURE 1 Scheme of PR-2.

Due to a mirror machine have magnetic anisotropy longitudinal EEDF differs from radial. And it is particularly evident for a beam-plasma discharge where we have high energy electrons from primary electron beam. As for radial EEDF is expected approximately thermal distribution, then for longitudinal the EEDF is more complex [5].

## EXPERIMENTAL SETUP

The experiments were carried out on the linear plasma device PR-2 (mirror ratio 1,55). Beam-plasma discharge is provided by electron beam up to 10 kV, power up to 10 kW. Measurements were carried out behind magnet mirror by especially design small-size integral electrostatic energy analyzer [3]. The analyzer has long circular tantalum diaphragm with small radius to cut ions off [4]. This material allows us use powerful regimes of PR-2. Other one features of this material is that further we can use it for generate and research EEDF in auto-oscillating modes [2].

All experiments were carried out under fixed parameters:

- Work gas – hydrogen
- Work pressure –  $7 \cdot 10^{-4}$  torr
- Electron beam gun emission current – 80 mA

The tantalum extended diaphragm with thickness of 2 mm and 0.37 mm inner diameter (Fig. 2) is mounted on the water-cooled collector with aperture. It allows to cut off ions with the larmor radius more than  $0.5d$ . Retarding electrode is made of wide metal plate with small aperture. The calculation shows that in this system distortion of an electric field is negligible. Retarding electrode was mounted on PTFE insulator with breakdown voltage more than 10 kV. Second electrode and current detector is the Faraday cup. The second emitted electrons from Faraday cup trapped by retarding potential in condition  $U_{ret} > 50$  V. Device was protected against parasite currents from plasma by stainless shield.

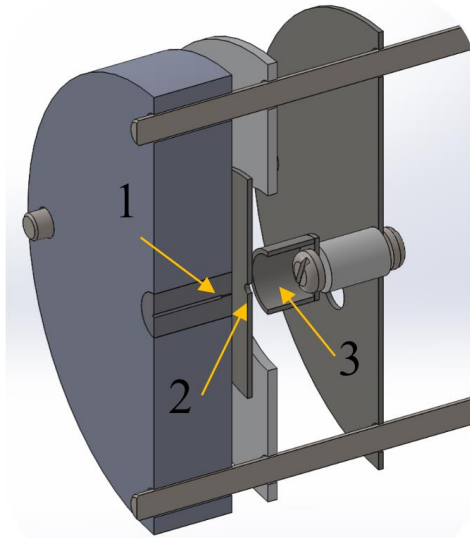

**FIGURE 2** View of energy analyzer: 1 Spread diaphragm, 2 Retarding electrode, 3 Faraday cup.

Unfortunately, this design of analyzer can't measure energy distribution of primary beam electrons with energy less than 50 eV. That occurs due to spread diaphragm emitting great number of second electrons. So it is impossible to distinguished temperature electrons from secondary electrons emitted from the diaphragm. Herewith majority of electrons is expected to be thermalized. But these electrons can be detected by other methods, for example Langmuir probe.

## RESULTS

The functionality of electron energy-analyzer was tested on usual for PR-2 the beam-plasma discharge. Longitudinal EEDF of PR-2 plasma were obtained by energy analyzer (Fig. 3). These spectra show two modes of beam-plasma discharge and transition zone:  $U_{accel}$  600 – 800 V and  $U_{accel}$  1100 – 1500 V. These data correspond to numerical calculations [5]. EEDF of the first mode (Fig. 3 a) has a subsequent linear decreasing and pronounced tail

of high-energy electrons. EEDF of the second mode is a wide peak with plateau at the top. This mode corresponds to numerical calculations [5]. In both cases considerable fraction of electrons has energy exceeding the beam energy. Also it important to remember that significant part of electrons probably thermalized and not presented on these spectra.

The obtained data is necessary for kinetic calculations of beam-plasma discharge and it allow us to determinate component composition of plasma in PR-2. It is required for interpret mass-spectra which receive by combined diagnostic module [6]. As result it is possible to correspond the relative fluxes on the surface with composition of plasma.

That shape of EEDF is expected for beam-plasma discharge, but numerical features can change due to the geometry of facilities and as a consequence the main plasma wave frequencies will differ.

The next step of research is a measure by EEDF for another conditions: work gases, gas pressures.

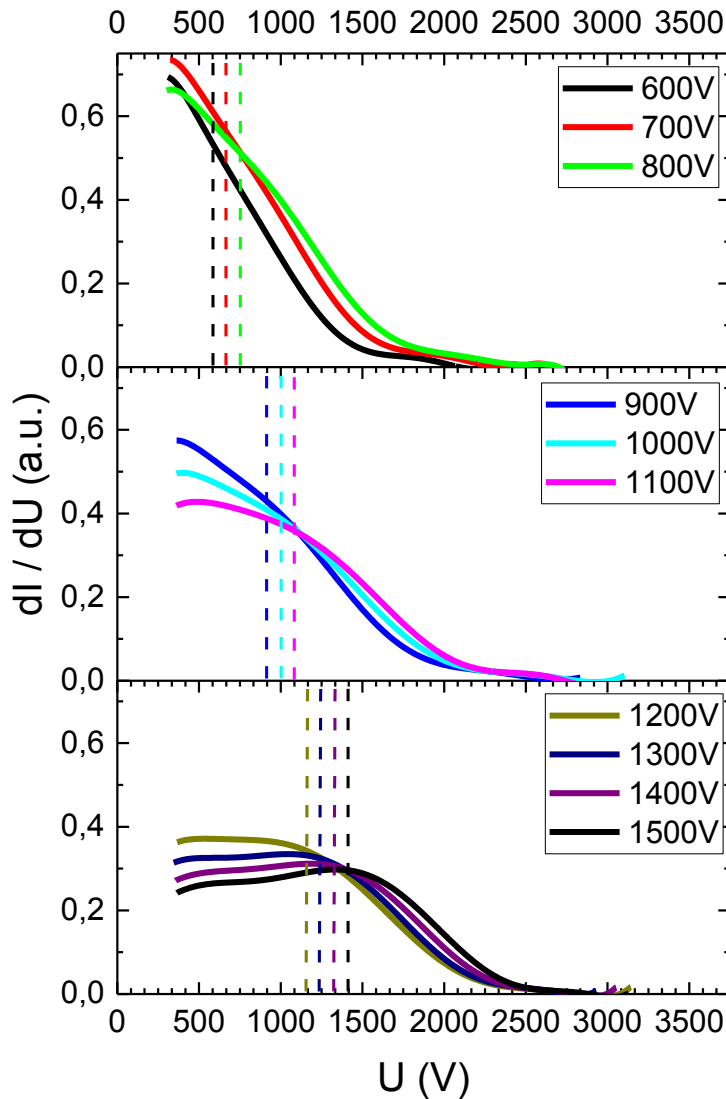

**FIGURE 2** Electron energy distribution function for different accelerating voltage of electron beam gun (600 – 1500 V), Dashed line show electron beam energy.

## CONCLUSION

We have designed and assembled the electron energy analyzer for plasma-beam discharge. It allows us to measure electron energy distribution in high energy range up to 10 kV.

Electrons energy distribution function has been measured in beam-plasma discharge for different accelerating voltages (600 – 1500 V) and constant emission current 80 mA and pressure  $10^{-4}$  torr. The two types of EEDF in plasma-beam discharge was observed:  $U_{\text{accel}}$  600 - 800 V and  $U_{\text{accel}}$  1100 - 1500 V.

Considerable fraction of electrons has energy exceeding the beam energy due to beam-plasma interaction.

## ACKNOWLEDGMENTS

The work was partly supported by the Competitiveness Growth Program of National Research Nuclear University MEPhI.

## REFERENCES

- [1] K. M. Gutorov, I. V. Vizgalov, E. A. Markina, and V. A. Kurnaev, *Influence of thin dielectric layers on electron emission and plasma-surface contact stability*. Bulletin of the Russian Academy of Sciences: Physics, **74**(2), pp. 188-191 (2010).
- [2] K. M. Gutorov, I. V. Vizgalov, and V. A. Kurnaev, *High-voltage pulse generation in the auto-oscillating discharge*. Applied Physics **6**, pp. 87-90 (2011).
- [3] I. H. Hutchinson, *Principles of Plasma Diagnostics, Second Edition*. (Cambridge University Press, 2002) pp. 94-99.
- [4] T. D. Akhmetov, V. I. Davydenko, and S. Y. Taskaev, *Measurements of the electron distribution function in the AMBAL-M startup plasma by an electrostatic analyzer*. Plasma Physics Reports, **26**(2), pp. 152-156 (2000).
- [5] A.A. Ivanov, *Scientific works*. (Moscow, “Phys-Mat literature”, 2012) pp. 169-172.
- [6] I. A. Sorokin, I. V. Vizgalov and O. A. Bidlevich, *In-situ mass-spectrometry of magnetized plasmas*. Physics Procedia, **71**, pp. 428-432 (2015).